

"Math Is Cool" Masters — 2021-22

8th Grade — April 27, 2022

Sponsored by: Columbia Basin College

GENERAL INSTRUCTIONS applying to all tests:

- *Good sportsmanship is expected throughout the competition by all involved (competitors and observers). Display of poor sportsmanship will result in disqualification.*
- *Competitors may not use calculators or any other aids on any portion of this contest.*
- *Unless stated otherwise:*
 - *Express all rational, non-integer answers as common fractions, except in problems dealing with money, where you should give the answer as a decimal rounded to the nearest cent.*
 - *For 5th grade and up, all fractions and ratios must be reduced to simplest form, all radicals must be simplified, and all denominators must be rationalized.*
 - *Do not round or approximate answers. Leave answers in terms of π or other irrational quantities (e.g., $\sqrt{2}$), where applicable.*
- *Units are not necessary as part of your answer, unless it is a problem that deals with time, in which case, AM or PM is required. However, if you choose to use units, they must be correct.*
- *Record all answers on the colored cover sheets in the answer column only.*
- *Be sure that the student name, school, team number, etc. has been filled out at the top of each answer sheet.*
- *Tests will be scored as a 0 if answers are not recorded correctly on the answer sheets.*
- *Blank answer sheets and answer sheets with no name will be scored as a 0.*

FINAL SCORES AND AWARDS

Individual awards are determined by both the Mental Math and Individual Test scores. Individual ties are broken based on the following, in this order: total scaled individual points, total number of correct answers on the Individual Test, Mental Math raw score, number of correct answers from Individual Test #31-40, number of correct answers from Individual Test #16-30, highest numbered question answered correctly on the Individual Test working backwards from #40.

Team (School) awards are based on the highest score from amongst each of the school's "teams of 4 students" in each event and is calculated as $2 \cdot (\text{Sum of highest 3 Mental Math scores}) + 2 \cdot (\text{Multiple Choice}) + 6 \cdot (\text{Team}) + 1 \cdot (\text{Triple Jump}) + 1 \cdot (\text{College Bowl})$, for approximate weights of 25%, 20%, 30%, 15% and 10% respectively. Team ties are broken based on highest event score in order of the events, starting with Mental Math.

MENTAL MATH TEST - 30 sec./quest., 8 problems, ~8%/25% of individ./team scores

The proctor will read each question twice. You may not do any writing or talking while arriving at a solution. Record only your answer on your answer sheet. You may not change, cross out, erase, or write over an answer once you have written it down. The maximum wait time is 30 seconds after completion of the second reading of the question. Correct answers receive 1 point.

INDIVIDUAL TEST - 35 minutes, 40 problems, ~92% of individual score

When you are prompted to begin, tear off the colored answer sheet and begin testing. No talking during this individual test. You will be given a 5 minute time warning. Correct answers receive 2 points for problems 1-30 and 3 points for 31-40 (in the scaled score).

"Math Is Cool" Masters – 2021-22

8th Grade – April 27, 2022

Sponsored by: Columbia Basin College

Final Score (out of 8)

Room # School Name Student Name Team #

Mental Math - ~25% of team score & ~8% of individual score

All students in the room will concurrently be asked the same eight questions in this individual test. When it is time to begin, the proctor will read the first question twice. You may not do any writing or talking while arriving at a solution. Once you have a solution, record it on the sheet in front of you. You may not change or cross out answers once you have written an answer down. If there are eraser marks, write-overs, or crossed-out answers, they will be marked wrong. Once all students have laid their pencils on the desk, another question will be asked. If a student doesn't lay his or her pencil down, the maximum wait time is 30 seconds after completion of the second reading of the question before the next question is read. You may continue to work on a problem (in your head) while the next question is being read. The raw score is 1 point per correct answer.

STUDENT: DO NOT WRITE IN SHADED REGIONS (or anywhere else, other than the answer box)

Answer		Scorer 2	Scorer 1
		0 or 1	0 or 1
1			
2			
3			
4			
5			
6			
7			
8			
8th Grade		TOTAL:	

"Math Is Cool" Masters — 2021-22

8th Grade — April 27, 2022

Sponsored by: Columbia Basin College

Key

Mental Math Contest - Answer Key

30 seconds per question - ~25% of team score & ~8% of individual score

SCORERS — Write-overs, Cross-outs, and Erasures Must be Marked Incorrect (0)
Bracketed items [...] in the answer key are optional.

8th Grade

Answer		
1	21 [in]	The area of a rectangle is sixty-three square inches. If the length of the rectangle is three inches, how many inches long is the width?
2	31 [quarters]	A stack of quarters has a value of seven dollars and seventy-five cents. How many quarters are in the stack?
3	3000	What is seventy-five times forty?
4	24 [=x]	If you multiply X by two and then divide the result by six, you get eight. What is the value of X?
5	11	Dana can complete one painting every five hours and she paints for ten hours a day. How many days will it take her to complete twenty-two paintings?
6	27	As a reduced common fraction, the probability that a red seven is selected when one card is drawn from a standard deck is A over B. What is the value of A plus B?
7	320	What is twenty-four squared minus sixteen squared?
8	263	What is the largest positive three-digit integer in which the ones digit is half of the tens digit, and the tens digit is three times the hundreds digit?

"Math Is Cool" Masters — 2021-22

8th Grade — April 27, 2022

Sponsored by: Columbia Basin College

Individual Contest

Record all answers on the colored cover sheet. 35 minutes, 40 problems, ~92% of individual score.

No talking during this individual test. A 5-minute time warning will be given.

Questions 1-30: 2 points each	
1	Evaluate: $1 * 2 * 3 * 4 * 10$
2	What is the value of x in the following equation? $7x - 35 = 126$
3	The number of cups of water that a 12-oz glass can hold is $A.B$, where A and B are each single-digit integers. What is the value of $A + B$?
4	What is the 8 th number in the arithmetic sequence whose first three terms are: $5, 11, 17, \dots$?
5	As a reduced common fraction, the probability that a randomly chosen letter from the letters in the words EENSIE WEENSIE is an N or an S is A/B . What is the value of $A + B$?
6	A palindrome is a number that reads the same forwards and backwards, for example 1221. How many palindromes are there between 50 and 200?
7	Evaluate: $15 + 30 - 60$
8	What is the median of the set of data given below: $13, 18, 12, 8, 23, 100, 19$
9	In a school with 120 students there are thirty 6th graders. What percentage of the students in the school are 6th graders?
10	Boris is waiting in line. There are three people in front of him and five people behind him. How many total people are in the line?
11	If $x > 19.875$, what is the smallest possible integer value of x ?
12	The product of $\frac{2}{5} * \frac{5}{16} * \frac{8}{27}$ as a reduced common fraction is A/B . What is the value of $A + B$?
13	How many integer values of N are there such that the expression $\frac{104}{N}$ represents a positive integer?

14	In the game of chess, a knight can move either one space right or left in combination with two spaces up or down, or two spaces right or left in combination with one space up or down. On the board shown, how many squares are possible landing spots for the knight?	
15	Two rectangles have a perimeter of 40 inches, but different areas. In square inches, what is the largest possible difference in the areas of the two rectangles, if side lengths must be integers?	
16	Evaluate: $(11 * 23 - 15) \div 14$	
17	Alonzo has read 35% of his book and he's on page 182. How many pages long is the book?	
18	It takes Anna 35 minutes to walk home from school. Her sister Jane rides her bike at an average rate that is 5 times Anna's average walking rate. In minutes, how long does it take Jane to ride home from school along the same route that Anna walks?	
19	Rows 0 through 4 of Pascal's Triangle are shown here. What is the sum of all the numbers that are not 1s in rows 0 through 5?	$ \begin{array}{c} 1 \\ 1 \ 1 \\ 1 \ 2 \ 1 \\ 1 \ 3 \ 3 \ 1 \\ 1 \ 4 \ 6 \ 4 \ 1 \end{array} $
20	The sum of the four fractions $\frac{7}{6}, \frac{7}{5}, \frac{7}{3}$ and $\frac{7}{2}$, as a reduced common fraction is A/B . What is the value of $A + B$?	
21	How many kilometers are equivalent to 1.375×10^9 millimeters? Give your answer as an integer.	
22	If $a \neq b = a - 2b$, and $(x \neq 3) \neq x = 19$, what is the value of x ?	
23	The figure shown here consists of 8 congruent squares. How many non-square rectangles of any size are there in the figure?	
24	Ayanna is looking at Raul and Raul is looking at Clarice. Ayanna owns a dog and Clarice does not, and we don't know whether Raul owns a dog. Is a dog-owner looking at someone who does not own a dog? Answer 1 for yes, 2 for no, and 3 for "cannot determine".	
25	What is the sum of the first 6 numbers in the geometric series that begins with: 1, 4, 16, ... ?	
26	What is the mean of the numbers represented in the stem and leaf plot shown here? Note: the numbers represented in row 1 are 12, 13, 14, and 16.	$ \begin{array}{r l} 1 & 2, 3, 4, 6 \\ 2 & 1, 3, 6, 8 \\ 3 & 0, 2, 4, 9 \end{array} $

27	Eight fair coins are flipped at the same time. What is the number of ways that heads could be showing on three of the coins and tails showing on the rest?
28	The base-10 number 512 equals the base-7 number A_7 , where A has four digits. What is the value of A?
29	The wheels on a bicycle have a diameter of 16 inches and on one occasion it is ridden for one mile, or 5280 feet. In terms of π and as a reduced fraction, the number of complete revolutions that each wheel makes during the ride is $\frac{A}{\pi}$. What is the value of A?
30	Consider the set $\{2, 3, 5, 7, 11, 13, 17, 19, 23, 29\}$. Let A be a number selected at random from the set and let B be a different number selected at random from the set. As a reduced common fraction, the probability that $A + B$ is a prime number is P/Q . What is the value of $P + Q$?

Challenge Questions: 3 points each

31	<p>In the figure, $\triangle ABC \sim \triangle EDA$. The '~' symbol means 'similar to', and this means that the vertices are named in corresponding order. In other words, vertex A from $\triangle ABC$ corresponds with vertex E from $\triangle EDA$, and so on. If $AE = 11$ cm, $BE = 44$ cm, and $AC = 27.5$ cm, then $DE = x$ cm. What is the value of x in centimeters?</p>	
32	<p>Consider an infinite series of digits represented by the expression $\dots abcabcabc\dots$, where a, b, and c, each represent distinct single-digit positive integers. How many such series are possible if a, b, and c must all be odd? Note: the infinite series $\dots 123123123\dots$, $\dots 231231231\dots$, and $\dots 312312312\dots$ would all be subsections of the same series and therefore would all count as one series.</p>	
33	<p>The complex fraction shown here expressed as a reduced common fraction is A/B. What is the value of $A + B$?</p>	$3 - \frac{2}{3 - \frac{2}{3 - \frac{2}{3 - \frac{2}{3}}}}$
34	<p>A standard deck of cards is divided into two piles, one with 26 red cards and one with 26 black cards. If two cards are randomly drawn from each pile, the probability as a reduced common fraction that the cards form four of a kind, for example, four 7s, four kings, four aces, etc., is A/B. What is the value of $A + B$?</p>	

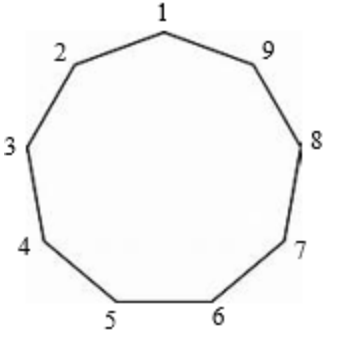
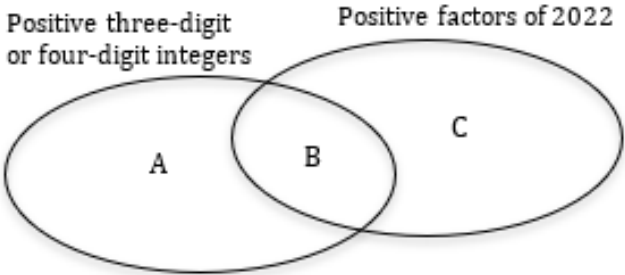
35	<p>A regular nonagon has 9 congruent sides and 9 congruent interior angles as shown. Bart draws a star by drawing a line segment from vertex 1 to vertex 3, then another line segment from vertex 3 to vertex 5, and so on, skipping one vertex each time until ending up back at vertex 1. This process creates two sets of congruent non-overlapping triangles. What is the total number of triangles combined in these two sets of non-overlapping triangles?</p>	
36	<p>What is the coefficient of the x^3y term when the expression $(5x - 11y)^4$ is written in expanded form?</p>	
37	<p>In the diagram below, let B represent the number of numbers that are both positive factors of 2022 and three-digit or four-digit integers. Let A represent the number of positive three-digit or four-digit integers that are not also factors of 2022 and let C represent the number of positive factors of 2022 that are not also three-digit or four-digit integers. What is the value of $A + B + C$?</p> <div style="text-align: center;">  </div>	
38	<p>A box contains only dimes and nickels. If there were 25% more nickels, there would be 8% more value to the money in the box. As a reduced common fraction, the ratio of the original number of dimes to the original number of nickels in the box is D/N. What is the value of $D + N$?</p>	
39	<p>A data set consists of only positive integers and has a mean of 40, a median of 65 and a unique mode of 75. What is the fewest possible number of values in the data set?</p>	
40	<p>A jar contains 11 marbles that are either red, green, or blue. If two marbles are randomly selected from the jar without replacement, the probability that they will be the same color is $\frac{21}{55}$. What is the largest number of marbles of any one color in the jar?</p>	
<p>IF taking Algebra or Geometry, continue to questions 41 - 42.</p>		
41	<p>The sum of the solutions to the equation $(2x - 5)(x - 7) = 26$ is A.B, where A and B are each single-digit integers. What is the value of $A + B$?</p>	
42	<p>A kayaker can row 4 miles upstream against a 1.5-mph current in one hour more than she can row 5 miles downstream. Her average speed in still water is A.B miles per hour, where A and B are each single-digit integers. What is the value of $A + B$?</p>	
<p>IF taking Geometry, continue to questions 43 - 45.</p>		

43

In the figure below $AB = BC$, and \overline{DE} is parallel to \overline{FG} . Also, \overline{DE} , \overline{CD} , and \overline{AB} all intersect at point D. Finally, $m\angle BCD = 34^\circ$, $m\angle CDE = 90^\circ$, and $m\angle FGH = 158^\circ$. What is the number of degrees in the measure of the angle labeled p?

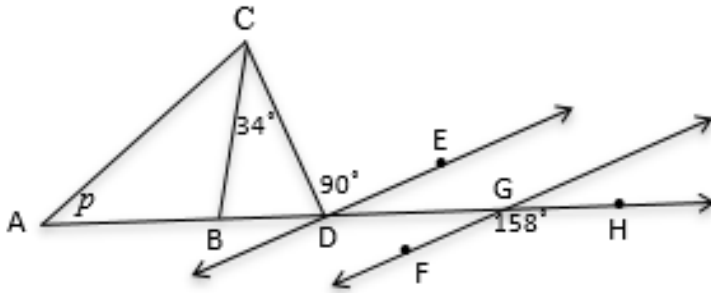

44

A construction worker drills eight holes through a concrete wall for drainpipes. The wall is 8 inches thick and each of the holes has a diameter of 3 inches. As a reduced fraction in and in terms of π , the number of cubic feet of combined space in the eight holes is $\frac{\pi}{A}$. What is the value of A?

45

In the figure shown below, there are three squares placed so that their top edges are aligned in a straight line. The medium-sized square has half the perimeter of the large square and the small square has half the perimeter of the medium-sized square. The area of the three squares combined is 189 cm^2 . In simplest radical form, the length of \overline{AB} is $P\sqrt{Q}$ cm. What is the value of $P + Q$?

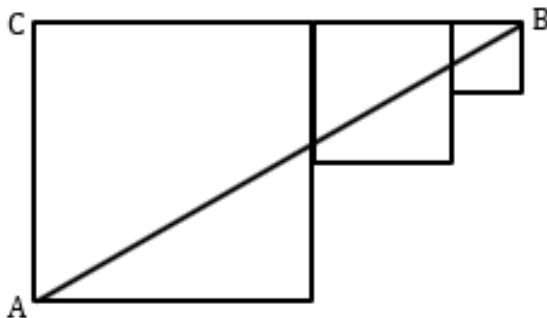

"Math Is Cool" Masters - 2021-22

KEY

Individual Contest - Answer Key

SCORERS: Bracketed [...] items in answer key are optional. Just mark the score as 0 or 1 and add up those values to reflect total correct.
First Scorer - use the right-hand columns so 2nd scorer can do a blind scoring.

	Answer
1	240
2	[x =] 23
3	[A + B =] 6
4	47
5	[A + B =] 17
6	15 [palindromes]
7	-15
8	18
9	25 [%]
10	9 [people]
11	[x =] 20
12	[A + B =] 28
13	8 [values]
14	8 [squares]
15	81 [in ²]

	Answer
16	17
17	520 [pages]
18	7 [minutes]
19	52
20	[A + B =] 47
21	1375 [km]
22	[x =] -25
23	19 [rectangles]
24	1
25	1365
26	24
27	56 [ways]
28	[A =] 1331
29	[A =] 3960
30	[P + Q =] 10

	Answer
31	[x =] 22 [cm]
32	20 [series]
33	[A + B =] 94
34	[A + B =] 8126
35	18 [triangles]
36	-5500
37	[A + B = C =] 9904
38	[D + N =] 33
39	9 [values]
40	6 [marbles]
41	[A + B =] 14
42	[A + B =] 8
43	39 [°]
44	[A =] 12
45	[P + Q =] 68

"Math Is Cool" Masters - 2021-22

Total Correct (all columns)

Room # _____ SCHOOL NAME _____ STUDENT NAME _____ Team # _____

Individual Contest - Score Sheet

STUDENTS: DO NOT WRITE IN SHADED REGIONS

	Answer	1 or 0	1 or 0
1			
2			
3			
4			
5			
6			
7			
8			
9			
10			
11			
12			
13			
14			
15			
1-15 TOTAL:			

	Answer	1 or 0	1 or 0
16			
17			
18			
19			
20			
21			
22			
23			
24			
25			
26			
27			
28			
29			
30			
16-30 TOTAL:			

	Answer	1 or 0	1 or 0
31			
32			
33			
34			
35			
36			
37			
38			
39			
40			
41			
42			
43			
44			
45			
31-45 TOTAL:			

"Math Is Cool" Masters — 2021-22

8th Grade — April 27, 2022

Sponsored by: Columbia Basin College

Team Multiple Choice Contest

REFER TO THE FOLLOWING INFORMATION FOR PROBLEMS #1 THROUGH #4.

The pattern of numbers in the following table continues infinitely. All rows have 9 numbers in them, and all columns continue infinitely. For example, row 1 has numbers 1 - 9 in it and column 1 has numbers 1, 10, 19, 28, 37, 46, 55, 64, . . . in it.

1	2	3	4	5	6	7	8	9
10	11	12	13	14	15	16	17	18
19	20	21	22	23	24	25	26	27
28	29	30	31	32	33	34	35	36
37	38	39	40	41	42	43	44	45
46	47	48	49	50	51	52	53	54
55	56	57	58	59	60	61	62	63
64	65	66	67	68	69	.	.	.
.

- 1 What is the median of the numbers in the first three rows?
A) 9.5 B) 13.5 C) 14 D) 14.5 E) 18.5
- 2 What is the sum of the numbers in the fourth row?
A) 288 B) 298 C) 320 D) 352 E) 576
- 3 How many rows are made up entirely of two-digit integers?
A) 9 B) 10 C) 11 D) 12 E) 13
- 4 Starting from and including row 1, how many consecutive rows of numbers would need to be added together such that the sum of all the numbers in those rows is more than 45,000?
A) 26 B) 33 C) 34 D) 39 E) 43

Continued on Next Page

REFER TO THE FOLLOWING INFORMATION FOR PROBLEMS #5 THROUGH #7.

The four points shown in the graph have their coordinates recorded in the table shown here. The line on the graph is the best-fit line and its equation is:

$$\hat{y} = \frac{4}{5}x + \frac{5}{2}$$

The symbol \hat{y} is called "y-hat" and is notation used in the equation of the best-fit line, also known as a linear regression equation.

x	y
1	3
2	5
3	4
4	6

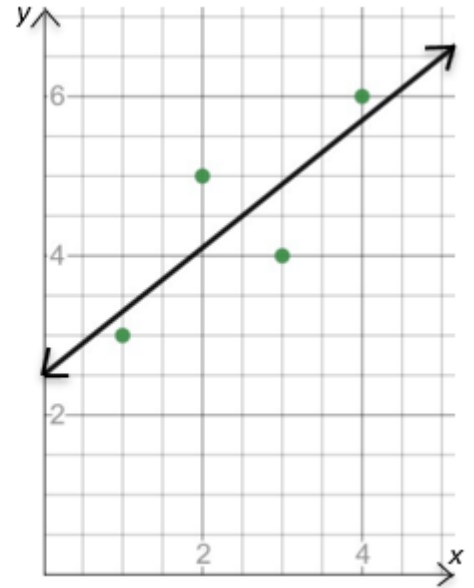

5 What are the coordinates of the two points that are in the half-plane below the best-fit line?

- A) (1, 3) & (2, 5) B) (1, 3) & (3, 4) C) (1, 3) & (4, 6)
 D) (2, 5) & (3, 4) E) (2, 5) & (4, 6)

6 According to the equation for the best-fit line, if $x = 1$ then $\hat{y} = 3.3$, if $x = 2$ then $\hat{y} = 4.1$, and so on. What is the value of \hat{y} if $x = 17$?

- A) $27/2$ B) 14.5 C) 15.1 D) 15.3 E) 16.1

7 On the graph shown here, four squares have been added, such that each square has one vertex at one of the four points and a second vertex directly below or above the point and on the best-fit line. What is the combined area of the four squares?

- A) 1.6 units^2 B) 1.625 units^2 C) 1.8 units^2
 D) 2.1 units^2 E) 7.4 units^2

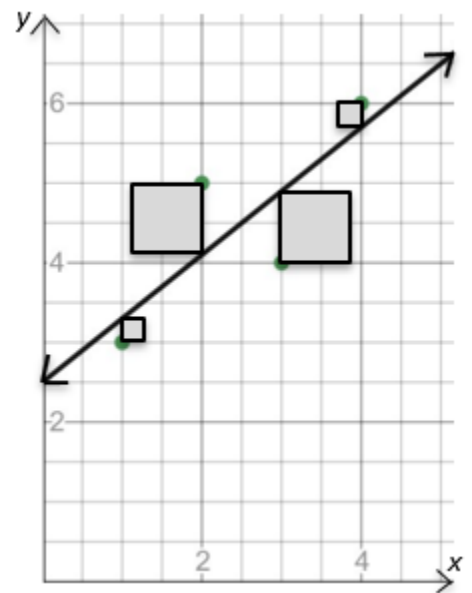

Continued on Next Page

USE THE FOLLOWING INFORMATION TO SOLVE PROBLEMS #8 THROUGH #10.

If $A \cap B$ = the sum of the common factors of A and B , then $27 \cap 36 = 13$, because the factors of 27 are 1, 3, 9, 27, the factors of 36 are 1, 2, 3, 4, 6, 9, 12, 18, 36, and the sum of the common factors is $1 + 3 + 9 = 13$.

If $A \cup B$ = the least common multiple of A and B , then $27 \cup 36 = 108$, because 108 is the smallest number that is evenly divisible by both 27 and 36.

8

What is the value of $20 \cap 30$?

- A) 12 B) 13 C) 17 D) 18 E) 21

9

What is the value of $(40 \cap 50) \cup 60$?

- A) 120 B) 180 C) 240 D) 300 E) 360

10

If $(x \cap y) \cup z = 77$, and x , y , and z are distinct positive integers, then what is the smallest possible value of $x + y + z$?

- A) 22 B) 23 C) 25 D) 28 E) 31

"Math Is Cool" Masters — 2021-22

8th Grade — April 27, 2022

Key

Team Multiple Choice Contest - Answer Key

8th Grade

Correct responses are worth 2 points, incorrect responses are worth -1 point, and absence of a response is worth 0 points.

	Answer
1	C
2	A
3	B
4	C
5	B
6	E
7	C
8	D
9	B
10	B

"Math Is Cool" Masters — 2021-22

8th Grade — April 27, 2022

Final Score (out of 20)

Room #

School Name

Team #

Team Multiple Choice Contest - 15 minutes - ~20% of team score

This test is the only test where you will be penalized for incorrect responses. You will receive two points for a correct letter response, zero points for leaving it blank, and minus one point for an incorrect response. When you are prompted to begin, tear off the colored answer sheet, pass out a copy of the test to each team member, and begin testing. ONLY a letter response should be listed as an answer on this answer sheet.

Correct responses are worth 2 points, incorrect responses are worth -1 point, and absence of a response is worth 0 points.

STUDENTS: DO NOT WRITE IN SHADED REGIONS

		Scorer 2	Scorer 1
Answer		-1, 0, or 2	-1, 0, or 2
1			
2			
3			
4			
5			
6			
7			
8			
9			
10			
8th Grade		TOTAL:	

"Math Is Cool" Masters — 2021-22

8th Grade — April 27, 2022

Sponsored by: Columbia Basin College

Team Contest

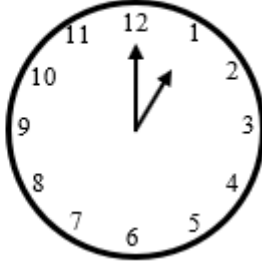
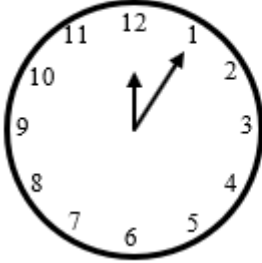
1	Twenty-three grizzly bears weigh the same as one African elephant and 32 African elephants weigh the same as one blue whale. How many grizzly bears weigh the same as one blue whale?
2	Evaluate: $10000 + 1000 + 100 + 10 + 1 - 9999 - 999 - 99 - 9$
3	A carton of cheesy crackers holds about 1633 crackers. How many handfuls would it take Tiny Tim to empty the carton, assuming he gets an average of 23 crackers per handful?
4	A square has an area less than 140 cm^2 . In centimeters, what is the largest possible integer length of one of the sides of the square?
5	What is the value of x in the following equation? $-50 + 3x = 35 - 2x$
6	Consider the infinite string of digits $\dots 02220222022202220 \dots$. The probability as a reduced common fraction that a randomly selected set of four adjacent digits is the number 2022 is A/B . What is the value of $A + B$?
7	<p>On a normal clock the hour (short) hand rotates 30° in one hour, while the minute (long) hand rotates 360° in one hour. On my clock, the hands are reversed, so the short hand is the minute hand, which takes one hour to rotate 360°, and the long hand is the hour hand, which takes one hour to rotate 30°. Between one PM and eleven PM on a single day, how many times does my clock show the correct time?</p> <p style="text-align: center;">My clock at 1:00 Normal clock at 1:00</p> <div style="display: flex; justify-content: space-around;"></div>
8	Zeke can wash a boat in 91 minutes. Yael can wash the same boat in 78 minutes. How many minutes would it take Zeke and Yael to wash the boat if they worked together?
9	A cylinder has a radius of 6 millimeters and a height of 14π millimeters. A continuous spiral begins at a point on the edge of the bottom base of the cylinder and ends at a point on the edge of the top base, directly above the point where it begins. The spiral is evenly spaced as it wraps around the cylinder exactly 4 complete times. The overall length of the spiral is $A\pi$ millimeters. What is the value of A ?
10	The expression $(2^{21} + 2^{20})(3^{21} - 3^{20})$, is equal to a 17-digit integer. What is the units digit of this integer?

"Math Is Cool" Masters — 2021-22

8th Grade — April 27, 2022

Key

Team Contest - Answer Key

8th Grade

	Answer
1	736 [grizzly bears]
2	5
3	71 [handfuls]
4	11 [cm]
5	[x =] 17
6	[A + B =] 5
7	10 [times]
8	42 [minutes]
9	[A =] 50
10	6

"Math Is Cool" Masters — 2021-22

8th Grade — April 27, 2022

Final Score (out of 10)

Room #

School Name

Team #

Team Contest - 15 minutes - ~30% of team score

When you are prompted to begin, tear off the colored answer sheet and give a copy of the test to each of your team members and begin testing. Each problem is scored as a 1 or 0. Record all answers on this colored answer sheet.

STUDENTS: DO NOT WRITE IN SHADED REGIONS

Answer		Scorer 2	Scorer 1
		0 or 1	0 or 1
1			
2			
3			
4			
5			
6			
7			
8			
9			
10			
8th Grade		TOTAL:	

"Math Is Cool" Masters — 2021-22

8th Grade — April 27, 2022

Sponsored by: Columbia Basin College

Linda Moore Triple Jump

1	A bag has 9 red, 12 orange, 11 yellow, 13 green, and 7 purple candies in it. As a reduced common fraction, the probability that a randomly selected candy is not orange is A/B . What is the value of $A + B$?																																										
2	The area of a circle with a radius of 34 cm is $X\pi$ cm ² . What is the value of X ?																																										
3	It takes Mably 12 minutes to walk home from school. Her school is $4/5$ of a mile from her house. What is her average rate in miles per hour during her walk from school to home?																																										
4	What is the positive solution for x in the following equation? $x^2 = \sqrt{625}$																																										
5	It takes 3 crews 20 days to paint 12 trucks. How many days would it take 5 crews to paint 11 trucks?																																										
6	<p>In the image of the month of June below, there are 35 individual rectangles making up the grid and five of the rectangles are empty. There are 10 distinct 3-by-3 arrays of 9 rectangles in this calendar month in which every rectangle contains a number. See the example below in which one of 3-by-3 arrays is outlined by a dashed rectangle. What is the sum of the numbers in the center rectangle in all of the 3-by-3 arrays?</p> <p style="text-align: center;">June 2022</p> <table border="1" style="margin-left: auto; margin-right: auto;"><thead><tr><th>Sun</th><th>Mon</th><th>Tue</th><th>Wed</th><th>Thu</th><th>Fri</th><th>Sat</th></tr></thead><tbody><tr><td></td><td></td><td></td><td>1</td><td>2</td><td>3</td><td>4</td></tr><tr><td>5</td><td>6</td><td>7</td><td>8</td><td>9</td><td>10</td><td>11</td></tr><tr><td>12</td><td>13</td><td>14</td><td>15</td><td>16</td><td>17</td><td>18</td></tr><tr><td>19</td><td>20</td><td>21</td><td>22</td><td>23</td><td>24</td><td>25</td></tr><tr><td>26</td><td>27</td><td>28</td><td>29</td><td>30</td><td></td><td></td></tr></tbody></table>	Sun	Mon	Tue	Wed	Thu	Fri	Sat				1	2	3	4	5	6	7	8	9	10	11	12	13	14	15	16	17	18	19	20	21	22	23	24	25	26	27	28	29	30		
Sun	Mon	Tue	Wed	Thu	Fri	Sat																																					
			1	2	3	4																																					
5	6	7	8	9	10	11																																					
12	13	14	15	16	17	18																																					
19	20	21	22	23	24	25																																					
26	27	28	29	30																																							
7	The average number of distinct positive integer factors for the numbers from 25 to 32 inclusive is $A.B$, where A is a single-digit integer and B is a three-digit integer. What is the value of $A + B$?																																										
8	In base-10, what is the sum of the 2-digit base-6 numbers that are greater than the largest 2-digit base-5 number? Do not include the base 10 in your answer.																																										

Continued on next page.

9 In the set of dots shown, the 4 horizontal and 5 vertical lines that could be drawn to contain the dots are equally spaced. If four different dots are selected at random, the probability that they are the vertices of a square as a reduced common fraction is A/B . What is the value of $A + B$?

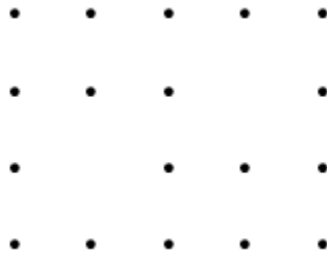

10 Two 2-cm-by-3-cm rectangles overlap as shown. As a reduced common fraction, the area of the shaded region is $A/B \text{ cm}^2$. What is the value of $A + B$?

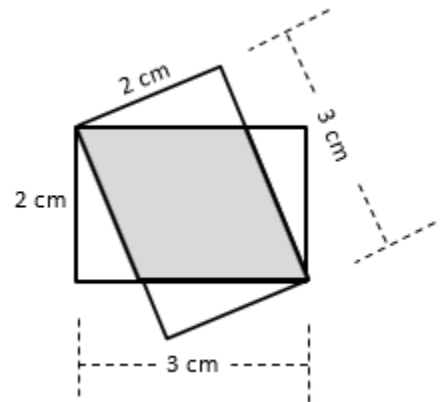

"Math Is Cool" Masters — 2021-22

8th Grade — April 27, 2022

Key

Linda Moore Triple Jump - Answer Key

8th Grade

	Answer
1	[A + B =] 23
2	[X =] 289
3	4 [mph]
4	[x =] 5
5	11 [days]
6	157
7	[A + B =] 379
8	330
9	[A + B =] 1537
10	[A + B =] 16

"Math Is Cool" Masters — 2021-22

8th Grade — April 27, 2022

Final Score (out of 10)

Room #

School Name

Team #

Linda Moore Triple Jump - 15 minutes - ~30% of team score

When you are prompted to begin, tear off the colored answer sheet and give a copy of the test to each of your team members and begin testing. Each problem is scored as a 1 or 0. Record all answers on this colored answer sheet.

STUDENTS: DO NOT WRITE IN SHADED REGIONS

Answer		Scorer 2	Scorer 1
		0 or 1	0 or 1
1			
2			
3			
4			
5			
6			
7			
8			
9			
10			
8 th Grade		TOTAL:	

"Math Is Cool" Masters — 2021-22

8th Grade — April 27, 2022

Room #

School Name

Team #

Total Score for Each Round

College Bowl #1 (10 Possible)	College Bowl #2 (10 Possible)	College Bowl #3 (10 Possible)

DO NOT USE TALLY MARKS ON THIS SHEET. WRITE THE TOTAL SCORE FOR EACH ROUND.

"Math Is Cool" Masters — 2021-22

8th Grade — April 27, 2022

Room #

School Name

Team #

Total Score for Each Round

College Bowl #1 (10 Possible)	College Bowl #2 (10 Possible)	College Bowl #3 (10 Possible)

DO NOT USE TALLY MARKS ON THIS SHEET. WRITE THE TOTAL SCORE FOR EACH ROUND.

"Math Is Cool" Masters — 2021-22

8th Grade — April 27, 2022

Sponsored by: Columbia Basin College

Proctor
Copy

Mental Math Contest

MENTAL MATH - 30 seconds per question - ~25% of team score & ~8% of individual score

*All students in the room will concurrently be asked the same eight questions in this individual test. When it is time to begin, the proctor will read the first question twice. You may not do any writing or talking while arriving at a solution. Once you have a solution, record it on the sheet in front of you. **You may not change or cross out answers once you have written an answer down. If there are eraser marks, write-overs, or crossed-out answers, they will be marked wrong.** Once all students have laid their pencils on the desk, another question will be asked. If a student doesn't lay his or her pencil down, the maximum wait time is 30 seconds after completion of the second reading of the question before the next question is read. You may continue to work on a problem (in your head) while the next question is being read. The raw score is 1 point per correct answer.*

1	The area of a rectangle is sixty-three square inches. If the length of the rectangle is three inches, how many inches long is the width?	21 [in]
2	A stack of quarters has a value of seven dollars and seventy-five cents. How many quarters are in the stack?	31 [quarters]
3	What is seventy-five times forty?	3000
4	If you multiply X by two and then divide the result by six, you get eight. What is the value of X?	24 [=x]
5	Dana can complete one painting every five hours and she paints for ten hours a day. How many days will it take her to complete twenty-two paintings?	11
6	As a reduced common fraction, the probability that a red seven is selected when one card is drawn from a standard deck is A over B. What is the value of A plus B?	27
7	What is twenty-four squared minus sixteen squared?	
8	What is the largest positive three-digit integer in which the ones digit is half of the tens digit, and the tens digit is three times the hundreds digit?	263

"Math Is Cool" Masters — 2021-22

8th Grade — April 27, 2022

Sponsored by: Columbia Basin College

Key

COLLEGE BOWL ROUND #1

#	Problem	Answer
1	If the sum of two numbers is sixty, and their difference is eight, what is the smaller of the two numbers?	26
2	Six wizards can conjure twenty-four castles in eighteen minutes. How many castles can three wizards conjure in six minutes?	4 [castles]
3	Evaluate six factorial divided by fifteen.	48
4	As a reduced common fraction, the probability of getting exactly two heads when flipping a coin four times is A over B . What is the value of A plus B ?	[$A + B =$] 11
5	Four ounces of salad dressing consist of forty percent vinegar and sixty percent oil. To make the dressing fifty percent vinegar, zero-point A ounces of vinegar need to be added, where A is a single-digit integer. What is the value of A ?	[$A =$] 8
6	Audrey is three-quarters of Sean's age. If Audrey was half of Sean's age eight years ago, how old is Sean now, in years?	16 [years]
7	Let A over B and C over D represent two fractions. A , B , C , and D are each replaced with a distinct integer from one through four. As a common fraction, the largest possible value of A over B minus C over D is E over F . What is the value of E plus F ?	[$E + F =$] 13
8	Rosa completes three-fourths of an assignment in eighty-seven minutes. How many minutes will it take her to complete what remains of the assignment, assuming she continues working at the same pace?	29 [minutes]
9	One million, two hundred nine thousand, three hundred forty-eight is multiplied by sixty-two million, three hundred eighty-seven thousand, four hundred fifty-three. What is the units digit of the result?	4
10	Four hundred students attend a certain university. Twenty percent of them are in their final year and eighty-five percent of those in their final year will graduate this year. How many students will graduate this year?	68 [students]

"Math Is Cool" Masters – 2021-22

8th Grade – April 27, 2022

Sponsored by: Columbia Basin College

Key

COLLEGE BOWL ROUND #2

#	Problem	Answer
1	What is twenty-two squared plus forty-four squared?	2420
2	The vertices of a triangle are located at one comma two, five comma two, and one comma eight on a coordinate plane. In square units, what is the area of the triangle?	12 [units ²]
3	If seven N plus seventeen equals twelve N plus seventeen, what is N?	0
4	Biff buys two lattes and one muffin for five dollars and fifty cents. Eho buys two hot chocolates and one muffin for four dollars and fifty cents. In dollars, what is the total cost of one latte, one muffin and one hot chocolate?	[\$] 5 [dollars]
5	One donut is equal to five bear claws. Two bear claws are equal to three apple tarts. How many donuts are equal to sixty apple tarts?	8 [donuts]
6	The scale of Kirby's map is such that one-fourth of an inch equals three miles. If the route Kirby plans to take is fourteen inches on the map, how far will Kirby actually travel, in miles?	168 [miles]
7	A bag contains twelve marbles, all of which are either black or white. As a reduced common fraction, the probability of pulling out two black marbles in a row without replacement is one over eleven. How many black marbles are in the bag?	4 [marbles]
8	How many cups are there in sixteen quarts?	64 [cups]
9	In inches, what is the height of a trapezoid with an area of twenty-seven square inches and bases of two and four inches?	9 [inches]
10	The cost of gasoline at the local gas station is three dollars and fifty cents per gallon. Naveen's car has a fifteen-gallon gas tank that is twenty percent full. How much will it cost Naveen to fill up the gas tank, in dollars?	42 [dollars]

"Math Is Cool" Masters — 2021-22

8th Grade — April 27, 2022

Sponsored by: Columbia Basin College

Key

COLLEGE BOWL ROUND #3

#	Problem	Answer
1	Evaluate five to the fifth power.	3125
2	Summer vacation lasts from June twenty-eighth to August twenty-third inclusive. How many days is this?	57 [days]
3	When the fraction $\frac{1}{7}$ is converted into a decimal number, what digit is in the 64 th place to the right of the decimal point?	8
4	Seventy-five percent of the number N is eighty-eight. What is three-eighths of N?	44
5	How many diagonals can be drawn in a convex nonagon?	27 [diagonals]
6	Rohan rolls three fair six-sided dice. As a reduced common fraction, the probability that there is a different number showing on each of the three dice is $\frac{A}{B}$. What is the value of $A + B$?	[$A + B =$] 14
7	Ana and Bea run in the same direction around the same track, and they start at the same place. To complete a lap, Ana takes one minute, and Bea takes forty-five seconds. After they start running, the first time that Ana and Bea are at the same starting point again at the same time is after Bea has completed N laps. What is the value of N?	4 [laps]
8	On the coordinate plane, what is the distance in units between the points located at (1, -3) and (-5, 5)?	10 [units]
9	Sonya's favorite book is nine hundred and thirty pages long and she reads at an average rate of one page every twenty seconds. How long does it take Sonya to read the book in minutes?	310 [minutes]
10	One full rotation around a circle equal to an angular measure of four hundred gradians. How many gradians are equivalent to forty-five degrees?	50 [gradians]

Proctoring Overview

You will receive a room packet envelope with the schedule and College Bowl rotations on the front. Each room packet includes:

- 1) the proctor instructions and the general instructions that you will be reading,
- 2) the proctor question/answers packet (this needs to be carefully controlled), and
- 3) sets of Mental Math, Individual, Multiple Choice, Team, and Relay test materials.
(If not in the room packet, the proctor supervisor will provide blank scratch paper.)

When you receive the room packet, count to ensure that you have the correct number of tests for each event (16 Mental Math & Individual, 4 of each of the team events).

Key Points

- Act professional; focus on what you are doing.
- Your job is to proctor the students; that is, you administer tests, give time warnings, & monitor students for proper test taking behavior to ensure competition integrity and avoid issues like failing to put answers on the answer sheet.
- The proctor packet has Mental Math, Relay, and College Bowl questions/answers. Keep the packet secure! Avoid opportunities for competitors to see the tests or answers.
- Student/school names and team numbers are critical on the answer sheets. Make sure that students fill out such identifying information.
- Keep track of time, and provide appropriate time warnings. Keep to the schedule as close as possible. Wait between events, if needed.
- Read & know the rules—competitors & spectators will, and they will call you on it.
- On questions that you read, read smoothly, enunciate clearly, and don't read too fast.
- You will score the Relays.
- If unsure of how to deal with an issue/question/concern, flag down the proctor supervisor and ask.
- Be respectful of your classroom — leave it tidy and arranged exactly as you found it. We don't want any displeased teachers!!
- Use the quick-reference guide on the next page for room setup and key information.

Schedule

Each of the 6 events includes about 5 minutes at the start for reading instructions or rearranging the room.

3:30 - 4:00	Coaches register (Library)	6:05 - 6:10	Relay #1
4:05 - 4:15	Orientation (Gym)		
4:15 - 4:20	Students go to testing rooms		
4:20 - 4:35	Mental Math		
4:35 - 5:15	Individual Test		
5:15 - 5:35	Team M.C. Test		
5:35 - 5:55	Team Test		
5:55 - 6:05	Relay Practice		

6:10 - 6:15	Relay #2	7:05 - 7:15	College Bowl #3
6:15 - 6:40	Proctors get dinner in proctor room	7:15 - 7:25	College Bowl #4
6:45 - 6:55	College Bowl #1	7:25 - 7:35	College Bowl #5
6:55 - 7:05	College Bowl #2	7:35 - 7:45	College Bowl #6
		8:00 - 8:30	Awards Ceremony (Gym)

1. Mental Math

Configuration: Students at individual desks spread out in the classroom. Alternating desks, students not next to teammates.

Scheduled Time: 4:20-4:35 PM (read instructions & test)

Duration: 30 seconds per question maximum (beginning after the 2nd reading)

Give Time warning at: 5 seconds

Number of questions: 8 (all students do the same questions)

Proctor Actions: Read each question twice, reading clearly and not too fast. Start the 30 second clock after the 2nd reading.

Key Points: Start by reading "General Instructions" then Mental Math instructions. Make sure everyone writes their name, school & team number on the answer sheet. No talking allowed. Except for the answer, no is writing allowed. Collect answer sheets and organize by team number, then alphabetically by first name of competitor, & staple sheets for the same team together.

2. Individual Test

Configuration: Students at individual desks; same arrangement as for Mental Math.

Scheduled Time: 4:35 PM (read instructions), 4:40-5:15 (test)

Duration: 35 minutes

Give Time warning at: 5 minutes & 30 seconds

Number of questions: 40

Proctor Actions: Ensure appropriate test-taking behavior. Prep for next event (or furtively read College Bowl questions to yourself).

Key Points: Read "Individual Test" instructions. Make sure everyone writes their name, team number, school, proctor name, & room number down on the answer sheet. Collect answer sheets, organize by team, then alphabetically by first name of competitor, and staple sheets for same team together.

3. Team Multiple Choice Test

Configuration: Groups of 4 desks, with the groups spread out in the classroom.

Scheduled Time: 5:15 PM (read instructions), 5:20-5:35 PM (test)

Duration: 15 minutes

Give Time warning at: 5 minutes & 30 seconds

Number of questions: 10

Proctor Actions: Ensure appropriate test-taking behavior. Prepare for next event.

Key Points: Read Mult. Choice instructions. Students can talk quietly & work together.

4. Team Test

Configuration: Groups of 4 desks spread out in the classroom (same as Team Mult. Choice).

Scheduled Time: 5:35 PM (read instructions), 5:40-5:55 PM (test)

Duration: 15 minutes

Give Time warning at: 5 minutes & 30 seconds

Number of questions: 10

Proctor Actions: Ensure appropriate test-taking behavior. Prepare for next event.

Key Points: Read Team Test instructions. Need to have school & team number on answer sheet. Students can talk quietly & work together.

5. Relay Tests

Configuration: Columns of 4 desks, one behind the other.

Scheduled Time: 5:55 PM (read instructions), 6:00-6:15 PM (test)

Duration: 5 minutes per relay

Give Time warning at: 30 seconds

Number of questions: 4 total per relay (~1 per person/relay)

Proctor Actions: Ensure appropriate test-taking behavior. Score Relays #1 and #2 at the end of each Relay (without showing any answers to students).

Key Points: No talking allowed. Students may not turn around. Students may only pass the answer sheet back (no work or notes). Proctor: circle the point value earned for each answer (0 or 1 or 2). Teams of 3 sit in positions 2, 3, & 4.

6. College Bowl

Configuration: Row of 9 desks (side by side) at the front of the room (CBA device on center desk).

Scheduled Time: 6:45 PM (read instructions), 6:50-7:45 PM (test)

Duration: 45 seconds per question (30 seconds per question if there is only one team, who will be only going against the clock)

Give Time warning at: 5 seconds

Number of questions: 10 per round, 6 rounds total

Proctor Actions: Read each question twice, reading clearly and not too fast. Start 45 (or 30) second clock after the 2nd full reading. Mark tally on white board as questions are answered and transfer the numeric total to the score sheets.

Key Points: Event is collaborative, talking is allowed. For a wrong answer, just say, "That is incorrect." (no verbal/visual clues that could be interpreted by the other team to arrive at an answer).

Summary of MIC Proctoring

(for proctors to read to themselves)

Pass out materials (answer sheet/test packets, scratch paper) for the current event to individuals or teams (as appropriate) so they can fill in the name, school, and team number information (very important!). Tell students to not lift the cover sheet or turn over the paper until you give the signal to start. Read the general instructions as the first item at the beginning of the competition (before Mental Math). Read the event-specific instructions just prior to each event and ask if there are any relevant questions. After reading the instructions, you can signal students to begin. Make sure one proctor is watching the time and giving appropriate time warnings (e.g., "five minutes remaining"). At the end of the event, tell competitors to stop work. Collect, sort, & staple the answer sheets (as appropriate) and keep them secure until handed off to a runner.

For the Mental Math/Individual tests, arrange students scattered throughout the classroom with **no student next to another student from their own school**. For the team tests, students will be in groups of 4 desks. The Relay will require the desks arranged in columns (front to back). College Bowl will require a line of 9 desks side-by-side across the front of the classroom.

For College Bowl, place the College Bowl apparatus (CBA) on a central desk in the line of desks at the front (4 desks on either side of the central one). One proctor will likely need to hold the CBA in place during the College Bowl rounds. Turn the apparatus on by depressing the button or flipping the dip switch. Students may try out the CBA prior to the 1st question. Note: while one light is blinking, the other light is locked out. There is no need to "reset" the device, just let the light finish blinking and it is ready to go.

Keep Relay answers secure while you score the Relays because answers for all three Relays are on the same sheet. Do not read the answer for College Bowl when you read the question (they are both on the same page). In College Bowl, if an incorrect answer is given, simply say "That is incorrect" and do not give any other cues about the answer (e.g., don't say "sorry, you were close" or exhibit interpretable body language). If both teams fail to supply a correct answer, announce what the correct answer was.

If there is an irregularity (i.e., lack of honesty, poor sportsmanship), make a note of the circumstances, flag the answer sheet, and report the issue to the proctor supervisor.

At the end of the day, return the desks to their original arrangement, recycle any unwanted test materials & used scratch paper, erase any marks you made on the whiteboard, and generally make sure the classroom is tidied up. Return the CBA, the room packet envelope, the proctor instructions, the contest rules packet, the proctor packet of questions, extra scratch paper, and unused test material to the proctor supervisor.

Detailed Instructions for Proctors

Grades 4-8

NO CALCULATORS ALLOWED ON ANY TESTS!

1. Check to make sure you have everything in your packet.
 - A. **Mental Math:**
 1. 16 - colored Mental Math answer sheets
 2. Mental Math questions with answers (in the Proctor Packet)
 - B. **Individual Test:** 16 individual tests, with colored answer sheets attached
 - C. **Team Multiple Choice Test:** 4 team multiple choice packets (stapled), each containing 4 tests plus one colored answer sheet on top
 - D. **Team Test:** 4 team test packets (stapled), each containing 4 tests plus one colored answer sheet on top
 - E. **Relays:**
 1. 4 - blank Relay answer sheet packets (with cover sheet/instructions)
 2. 4 - Practice Relay test sets, 4 - Relay #1 test sets, and
4 - Relay #2 test sets (each set has 4 sheets for positions 1-4)
 3. Relay Answer Key (in the Proctor Packet)
 - F. **College Bowl:**
 1. 4 - College Bowl score sheets
 2. College Bowl questions - 6 rounds (in the Proctor Packet)
 - G. Scratch paper (to be handed out as needed, but try not to waste it)
 - H. Electronic College Bowl Apparatus (CBA; usually distributed at dinner break)

ALL COLORED ANSWER SHEETS WILL BE COLLECTED BY YOU AND WILL BE TAKEN TO THE SCORING ROOM (by RUNNERS) AS SOON AS THEY ARE FILLED OUT BY COMPETITORS (AND PERHAPS GRADED BY YOU). COMPETITORS CAN KEEP ALL OF THE WHITE SHEETS, IF THEY WOULD LIKE (OTHEWISE COLLECT THEM FOR RECYCLE).

If you are missing anything, you can go get it before the opening ceremony. After the opening ceremony, contact the proctor supervisor/scoring room.

2. Take a photo or draw a picture on the whiteboard of how the classroom is laid out (so that it can be returned to its original configuration following the competition). Then set up the classroom desks for the first event (Mental Math).

Respect the teacher whose room you are using. Do not touch their computer or other items. Do not erase anything on their board. Leave the room tidy & in the exact original layout.

Mental Math

3. Arrange desks in a configuration suitable for individual testing (rows/grid of desks all facing forward, students in separated/alternating desks).

4. Put the Mental Math answer sheets face up on the desks such that students are spread out. Wait for students to arrive. You can fill out the proctor name and room number (and perhaps team numbers) on all blank answer sheets, if you like. Read over the questions so you will be prepared to read them out loud.
5. After students sit down, check to make sure that no one from the same team is seated next to each other (i.e., "Team xxx, raise your hands."). Ask them to move, if needed.
6. **Check to make sure that students put their full name, school name, team number, and room number on their answer sheet and that the information is legible.**
7. Read the "GENERAL INSTRUCTIONS" (in the Proctor Packet) to the students. Then, read the "MENTAL MATH" instructions (in the Proctor Packet) to the students.
8. Begin the testing. Read each of the eight Mental Math questions to all of the students in the room, per the instructions.
9. At the conclusion of Mental Math, collect the answer sheets. Organize the answer sheets by team number, then alphabetically by first name of competitor. Staple each team's set of four answer sheets together. Promptly hand the packets of answer sheets to your runner for conveyance to the scoring room.

Individual Test

10. The seating configuration will remain unchanged (no swapping seats).
11. Hand out Individual Test packets with the colored blank answer sheet facing up. **Check to make sure that students put their full name, school name, team number, and room number on their answer sheet and that the information is legible.**
12. Read the "INDIVIDUAL TEST" instructions (in the Proctor Packet) to the students and begin the testing at the appointed time.
13. While students are taking the Individual Test, monitor the students for proper test-taking behavior and watch the time to provide 5-minute and 30-second warnings. Make sure students are writing answers on the answer sheet (not the test question pages). During this time you can also get the Individual Multiple Choice tests ready, read through the rules of subsequent events, and (carefully/secretively) look ahead to review the College Bowl questions (i.e., to avoid stumbling over the wording when it comes time to read the questions aloud). You will have observers in the room watching the College Bowl rounds, so make sure you understand the rules, how timing works, etc.
14. At the conclusion of Individual Test, collect the answer sheets. Organize the answer sheets by team number, then alphabetically by first name of competitor. Staple each team's set of four answer sheets together. Promptly hand the packets of answer sheets to your runner for conveyance to the scoring room. Students may keep or recycle their test question packets.

Team Multiple Choice

15. Change the room set-up to groups of 4 desks together so students can work as a team.
16. Hand out the tests and have teams fill out the top portion of the answer sheet. **Check answer sheets to make sure they are filled out correctly (school, team #, etc.).**
17. Read the "TEAM MULTIPLE CHOICE" instructions (in the Proctor Packet) to the students and begin the testing at the appointed time.
18. Monitor the students for proper test-taking behavior (talking is allowed), watch the time, and provide 5-minute and 30-second warnings. While students are taking the Team Multiple Choice test, get the Team Tests ready.
19. At the conclusion of the test, collect the answer sheets & hand them off to the runner.

Team Test

20. Keep the same seating arrangement in groups of four. Hand out the Team Test packets and have teams fill out the information at the top of the colored answer sheet. **Check the answer sheets to make sure they are filled out correctly (school, team #, etc.).**
21. Read the "TEAM TEST" instructions (in the Proctor Packet) to the students and begin the testing at the appointed time.
22. Monitor the students for proper test-taking behavior (talking is allowed), watch the time, and provide 5-minute and 30-second warnings. While students are taking the Team Test, get the Relay tests ready.
23. At the conclusion of the test, collect the answer sheets & hand them off to the runner.

Relay Tests

24. Arrange each team of four students so that their desks are right behind each other and all facing the front of the room. For example, person 1 will be at the front of the line facing the front of the room. Person 2 will be right behind person 1 so that they are facing the back of person 1's head, etc. Teams of three sit in positions 2, 3, and 4. Teams of two sit in positions 2 and 4.
25. Pass out the packet of answer sheets to person 1 of each team. Have them fill out the top of all three answer sheets. They will use these sheets to record **only their final answer** and will pass only this answer sheet back to the next person. There is **NO TALKING** during the Relays and students **MAY NOT** look behind them - they must always be facing forward. Students may not change positions, nor leave the room, between Relays.
26. Once the top of the answer sheets are filled out, you may pass out the practice Relay questions to the appropriate people. Make sure person 1 gets the "person 1" piece of paper, etc. The questions must remain face down until it is time to start.

27. Read the "RELAY" instructions (in the Proctor Packet) to the students and begin the testing at the appointed time.
28. Once the Relay begins, everyone from the team may turn their sheet over and start working. They can use their slip of paper for scratch paper and it must never be passed back to the next person. The time allotted for each Relay is 5 minutes, so be sure you keep track of the time. Position yourself behind person 4 and be ready to collect each team's answer sheet once they complete the Relay or the time is up.
29. PRACTICE RELAY — This round is being done to teach the students how to do the math Relays, so this round is **not** to be scored. Address any questions that arise and correct the students if they misunderstood the procedures. Practice Relay answer sheets may be recycled.
30. RELAY #1 — Make sure that you are passing out Relay #1. Make sure the question sheets are face down and that each person has the correct sheet (i.e., person 1 has the person 1 sheet, etc.).

Scoring: Questions #1, #2, #3: 1 point if the answer is correct

Question #4: 2 points if the answer is correct

Total possible: 5 points for each Relay round

Circle the points for each question and fill in the total on the answer sheet. Lay out all of the answer sheets from this Relay so you can pair up the Relay #2 sheets by team.

31. RELAY #2 — Repeat the same process as for Relay #1.
32. At the conclusion of Relay #2, release the students for their break. Staple the pairs of answer sheets for each team together and hand off the set of Relay answer sheets to the runner. If there is anything left (i.e., answer sheets) that should have been taken to the scoring room, give those to the runner or have a proctor take it to the scoring room now.
33. Set up your room for the College Bowl rounds and tidy up the room before you go to break. Set up a line of 9 desks side by side facing the front of the room. One team will be on each side (doesn't matter which) and the College Bowl apparatus will be stuck down on the desk in the middle. Another row of 8 desks should be set up in the middle of the room for the two teams not competing in a round. Other desks should be moved to the back of the room in an orderly fashion for the spectators.
34. Take your packet of College Bowl questions with you during break to keep them secure! Do not leave them in the room!

Dinner Break

35. AT BREAK — Eat dinner in the proctor room. Pick up your College Bowl apparatus (CBA) at this time. If you haven't already, you may want to read over the College Bowl questions to make sure you will be able to pronounce everything properly. Return to your room in time to place the CBA in position.

College Bowl Rounds

36. Place the CBA on the middle desk of the line at the front of the room (you may want to moisten the suction cups with a film of water). One proctor may need to hold the device down (and do timing). Do not press the button to "reset" the CBA (it's an on/off switch).
37. You will have the same teams that were previously in the room for the duration of all College Bowl rounds — if you have an extra/different team, they are in the wrong room and can be disqualified if they hear the questions! Help get them to the correct room.
38. Fill out the score sheets for each team in your room with their school name and team number. Call up the first 2 teams according to the sequence on the room envelope.
39. You will be reading Round #1 questions to two teams while the other two teams (and any spectators) wait in the back of the room out of line of sight of the competitors. Refer to the College Bowl schedule (on your room envelope) to see which two teams compete in each round. If a round only has one team, they will be competing against the clock and thus will have 30 seconds to answer, not 45 seconds. Record the final scores for each team on their score sheets (which you hold on to) after each round. Rounds 2-6 work the same way. Refer to the schedule to make sure the correct teams are competing at the correct time. Don't get ahead of schedule (or behind, for that matter!). If you finish a round early, please wait until the appointed time to start the next round. If you have any problems (including anyone questioning the rules or a decision made by a proctor) contact the proctor supervisor.
40. Who is keeping score? Who is keeping track of the time? YOU ARE !!!
41. Read the "COLLEGE BOWL" instructions (in the Proctor Packet) to all the students (just one time), then begin the testing for each round at the appointed times.
42. If you mis-read a question, replace it with one of the extra questions.
43. If a parent/coach/student protests an answer, make a note of the situation (the test, the problem number, who answered, what their answer was, etc.) and kindly state that the coach should bring up the issue with the contest director. Proceed as normal, scoring the question based on the answer key.
44. At the conclusion of all College Bowl rounds, get the score sheets promptly to the scoring room (either yourself or via a runner).
45. Release your group to the awards ceremony no earlier than 7:45 PM to avoid causing a disruption to other rooms. Have students help re-set the room.
46. At the end of the day, return the desks to their original arrangement, collect all scratch paper, erase any marks you made on the whiteboard, and generally make sure the classroom is tidied up. Return the College Bowl apparatus, proctoring envelope, and residual material to the proctor supervisor.

General Instructions

- Good sportsmanship is expected throughout the competition by all involved (competitors and observers). Display of poor sportsmanship will result in disqualification.
- Competitors may not use calculators or any other aids on any portion of this contest.
- Unless stated otherwise:
 - Express all rational, non-integer answers as common fractions, except in problems dealing with money, where you should give the answer as a decimal rounded to the nearest cent.
 - For fifth grade and up, all fractions and ratios must be reduced to simplest form, all radicals must be simplified, and all denominators must be rationalized.
 - Do not round or approximate answers. Leave answers in terms of π or other irrational quantities (e.g., $\sqrt{2}$), where applicable.
- Units are not necessary as part of your answer, unless it is a problem that deals with time, in which case, AM or PM is required. However, if you choose to use units, they must be correct.
- Record all answers on the colored cover sheets in the answer column only.
- **Be sure that the student name, school, team number, etc. has been filled out at the top of each answer sheet.**
- Tests will be scored as a 0 if answers are not recorded correctly on the answer sheets.
- Blank answer sheets and answer sheets with no name will be scored as a 0.

Mental Math Instructions

All students in the room will concurrently be asked the same eight questions in this individual test. When it is time to begin, the proctor will read the first question twice. You may not do any writing or talking while arriving at a solution. Once you have a solution, record it on the sheet in front of you. **You may not change or cross out answers once you have written an answer down. If there are eraser marks, write-overs, or crossed-out answers, they will be marked wrong.** Once all students have laid their pencils on the

desk, another question will be asked. If a student doesn't lay his or her pencil down, the maximum wait time is 30 seconds after completion of the second reading of the question before the next question is read. You may continue to work on a problem (in your head) while the next question is being read. The raw score is 1 point per correct answer.

Individual Test Instructions

You will have 35 minutes to work on the Individual test, which consists of 40 questions. When you are prompted to begin, tear off the colored sheet and begin testing. Make sure your name and school are recorded on the answer sheet. The first 30 questions are worth two points each and questions 31-40 are worth 3 points each. Record your answers on the score sheet. No talking during the test. You will be given a 5 minute warning.

Team Multiple Choice Instructions

You will have 15 minutes to answer 10 multiple choice questions as a team. This test is the only test where you will be penalized for incorrect responses. You will receive two points for a correct letter response, zero points for leaving it blank, and minus one point for an incorrect response. When you are prompted to begin, tear off the colored answer sheet, pass out a copy of the test to each team member, and begin testing. **ONLY a letter response should be listed as an answer on this answer sheet.**

Team Test Instructions

You will have 15 minutes to answer 10 questions as a team. When you are prompted to begin, tear off the colored answer sheet and give a copy of the test to each of your team members and begin testing. Each problem is scored as a 1 or 0. Record all answers on this colored answer sheet.

Relay Instructions

There is no talking during this event and you must always be facing forward.

Person #1 will be given answer sheets and will need to fill out the top portion of each. The proctor will hand out a strip of paper to each person. These need to be face down on your desk until it is time for the Relay to start. Once the Relay begins, everyone may turn over their strip of paper and begin working, but first make sure you have the right person number.

Person #1 receives a full problem to solve. Questions 2-4 will be missing a number and will show the acronym "TNYWG" (meaning "the number you will get") [*Proctor: write this on the board*] as a placeholder in the problem statement. The answer for the previous question (i.e., received from the teammate in front of you) should be inserted into the problem statement in place of "TNYWG."

Person #1 will have problem #1 on his/her paper. Person #2 will have problems #1 and #2 printed on his/her paper. Person #3 will have problems #2 and #3 on his/her paper and Person #4 will have problems #3 and #4 on his/her paper.

You may write on the strip of paper to come up with answers to the problems on your strip of paper. However, when person #1 figures out his/her problem, he/she will record **ONLY** his/her final answer on the answer sheet and pass only the answer sheet back (without turning around) to the person #2.

Person #2 has the option of changing Person #1's answer if he/she wants, by crossing it out and putting a new answer. Once Person #2 records at least an answer for problem #2 on the answer sheet, he/she passes only the answer sheet behind to Person #3. Repeat these steps until person #4 puts an answer on the answer sheet and gives it to the proctor.

Each teammate has the option of changing any answers on the answer sheet when they have it in their possession, but once it is passed back, they will not see the answer sheet again.

Teams with only three members can position themselves in positions 2, 3, and 4 to provide answers for all four problems. Teams of two can sit in positions 2 and 4.

The raw score will be 1 point for correct answers to problems 1-3 and 2 points for question 4. Any non-answer text (i.e., scratch work or notes) on the answer sheet will result in a score of 0 for the entire Relay.

College Bowl Instructions

Read these to the competitors before the first round:

To maintain the integrity of the competition, spectators must stay in this room during a round of College Bowl questions. Once all readings for a round have been completed, you may leave.

All competitors must be facing the front of the room in one row. Teams not competing in the current round need to be behind the front row and in front of the spectators. All spectators need to be behind the competitors at the back of the room.

A maximum of ten questions per round will be scored. It is OK for both teams to score the same number of points! The proctor will record the points earned on each team's score sheet, which is retained by the proctor.

You may use scratch paper and pencil. You may talk with your team members while arriving at a solution.

An Electronic College Bowl Apparatus (CBA) will be used to identify the team who is first to have an answer.

During these rounds, each question will be read twice and a maximum time of 45 seconds after the second reading of the question is completed will be allowed for a team to answer. If a team buzzes in after the second reading and gives an incorrect response, the other team has the remainder of the 45 seconds to respond. A team is allowed only one attempt at buzzing in and answering per question. You may interrupt (buzz in) while a question is being read, however, if you do, the proctor will stop reading, and an immediate response is needed. If the correct response is given, the proctor will proceed to the next question. Otherwise, the question will be re-read for the other team, making sure it has two full readings. If an immediate response is not given after a team buzzes in, their lack of an answer in a timely manner is considered incorrect. In the event that only one team is competing in a round (i.e., one team is absent), the team competing will have a maximum of 30 seconds after the completion of the second reading in which to buzz in. The proctor will give a 5-second time warning.

Wait to be acknowledged by the proctor before giving an answer. This avoids the situation of blurting out an answer when the other team buzzed in first.

If two students from the same team answer at the same time with different answers, the answer will be considered incorrect.

If a problem arises with one of the questions, an extra question will be asked to replace that question.

If the round finishes early, you need to stay in the room for the remaining time.

Mental Math Questions

Relay Answers

College Bowl Questions/Answers