

# "Math Is Cool" Championships — 2022-23

9/10<sup>th</sup> Grade — October, 2022

Sponsored by:

## **GENERAL INSTRUCTIONS applying to all tests:**

- *Good sportsmanship is expected throughout the competition by all involved (competitors and observers). Display of poor sportsmanship will result in disqualification.*
- *Competitors may not use calculators or any other aids on any portion of this contest.*
- *Unless stated otherwise:*
  - *Express all rational, non-integer answers as common fractions, except in problems dealing with money, where you should give the answer as a decimal rounded to the nearest cent.*
  - *For 5<sup>th</sup> grade and up, all fractions and ratios must be reduced to simplest form, all radicals must be simplified, and all denominators must be rationalized.*
  - *Do not round or approximate answers. Leave answers in terms of  $\pi$  or other irrational quantities (e.g.,  $\sqrt{2}$ ), where applicable.*
- *Units are not necessary as part of your answer, unless it is a problem that deals with time, in which case, AM or PM is required. However, if you choose to use units, they must be correct.*
- *Record all answers on the colored cover sheets in the answer column only.*
- *Be sure that the student name, school, team number, etc. has been filled out at the top of each answer sheet.*
- *Tests will be scored as a 0 if answers are not recorded correctly on the answer sheets.*
- *Blank answer sheets and answer sheets with no name will be scored as a 0.*

## **FINAL SCORES AND AWARDS**

*Individual awards are determined by both the Mental Math and Individual Test scores. Individual ties are broken based on the following, in this order: total scaled individual points, total number of correct answers on the Individual Test, Mental Math raw score, number of correct answers from Individual Test #31-40, number of correct answers from Individual Test #16-30, highest numbered question answered correctly on the Individual Test working backwards from #40.*

*Team (School) awards are based on the highest score from amongst each of the school's "teams of 4 students" in each event and is calculated as  $2 \cdot (\text{Sum of highest 3 Mental Math scores}) + 2 \cdot (\text{Avg. of Top 3 Ind. Multiple Choice}) + 6 \cdot (\text{Team}) + 2 \cdot (\text{Pressure}) + 1 \cdot (\text{College Bowl})$ , for approximate weights of 25%, 20%, 30%, 15% and 10% respectively. Team ties are broken based on highest event score in order of the events, starting with Mental Math.*

## **MENTAL MATH TEST** - 30 sec./quest., 8 problems, ~8%/25% of individ./team scores

*The proctor will read each question twice. You may not do any writing or talking while arriving at a solution. Record only your answer on your answer sheet. You may not change, cross out, erase, or write over an answer once you have written it down. The maximum wait time is 30 seconds after completion of the second reading of the question. Correct answers receive 1 point.*

## **INDIVIDUAL TEST** - 35 minutes, 40 problems, ~92% of individual score

*When you are prompted to begin, tear off the colored answer sheet and begin testing. No talking during this individual test. You will be given a 5 minute time warning. Correct answers receive 2 points for problems 1-30 and 3 points for 31-40 (in the scaled score).*

# "Math Is Cool" Championships — 2022-23

9/10<sup>th</sup> Grade — October, 2022

Final Score (out of 8)
------------------------

Room #	School Name	Student Name	Team #
--------	-------------	--------------	--------

## Mental Math - ~25% of team score & ~8% of individual score

All students in the room will concurrently be asked the same eight questions in this individual test. When it is time to begin, the proctor will read the first question twice. You may not do any writing or talking while arriving at a solution. Once you have a solution, record it on the sheet in front of you. You may not change or cross out answers once you have written an answer down. If there are eraser marks, write-overs, or crossed-out answers, they will be marked wrong. Once all students have laid their pencils on the desk, another question will be asked. If a student doesn't lay his or her pencil down, the maximum wait time is 30 seconds after completion of the second reading of the question before the next question is read. You may continue to work on a problem (in your head) while the next question is being read. The raw score is 1 point per correct answer.

**STUDENT: DO NOT WRITE IN SHADED REGIONS (or anywhere else, other than the answer box)**

Answer		Scorer 2	Scorer 1
		0 or 1	0 or 1
1			
2			
3			
4			
5			
6			
7			
8			
<b>9/10<sup>th</sup> Grade</b>		<b>TOTAL:</b>	

# "Math Is Cool" Championships — 2022-23

9/10<sup>th</sup> Grade — October, 2022

Key

## Mental Math Contest - Answer Key

30 seconds per question - ~25% of team score & ~8% of individual score

**SCORERS — Write-overs, Cross-outs, and Erasures Must be Marked Incorrect (0)**  
Bracketed items [...] in the answer key are optional.

### 9/10<sup>th</sup> Grade

Answer		
1	32 [%]	Due to inflation, the owners of Hill's Bait shop raised the prices of their nightcrawlers by 10% in July. In August, they raised the prices by an additional 20%. What was the overall increase in percent?
2	13	In the equation $3^x = 1000$ (read as: 3 raised to the x equals 1000), the value of x that makes the equation true lies between two consecutive integers A and B. What is A + B?
3	-24	What is the y-coordinate of the vertex of the parabola described by the function: $f(x) = x^2 - 10x + 1$ (read as: x-squared minus 10x plus 1)
4	80 [units]	What is the sum, in units, of the lengths of all of the edges of a rectangular prism that measures 4 units wide by 7 units tall by 9 units deep.
5	15	An arithmetic sequence has a common difference of 4. The sum of the first two terms in the sequence is 10. What is the value of the 4 <sup>th</sup> term in the sequence?
6	9	Two cards are randomly selected from a standard deck of playing cards, with replacement. The probability that one of them is a heart and one of them is a diamond can be written as a reduced common fraction A/B (read as: A over B). What is A + B?
7	61 [cows]	A farmer was counting his cows. The first herd was consecutively numbered 45 through 83. The second herd was consecutively numbered 191 through 213, except cow number 211 was missing. How many total cows were there?
8	624 [base 10]	Expressed as a base 10 number, what is the largest 4 digit base 5 number? Do not include the base 10 in your answer.

# "Math Is Cool" Championships — 2022-23

October, 2022

## High School Individual Contest

35 minutes, 40 problems, ~92% of individual score.

A 5-minute time warning will be given.

Questions 1-30: 2 points each	
1	What is the slope of the line given by the following equation: $12x + 3y = 2$
2	What is $\frac{5}{3}$ of 621?
3	The volume of a right rectangular pyramid is $20 \text{ cm}^3$ . If the length, width and height of the pyramid are all tripled to create a larger, similar pyramid, what is the volume of the larger pyramid in cubic centimeters?
4	A 12-sided die contains the numbers 1 through 12. When the die is rolled once, what is the probability in percent that the number showing is a factor of 12?
5	What value of 'a' satisfies the following equation? $\frac{7!}{4!(7-a)!} = 105$
6	The parabola described by the following function has its vertex at the point (x, y). What is $x + y$ ? $F(x) = (x - 3)^2 - 1$
7	The lengths of the legs of a right triangle are 10 and 8 units. The length of the hypotenuse can be written in simplified radical form as $A\sqrt{B}$ . What is $A + B$ ?
8	Andrea is stacking up her identical patio chairs. One chair by itself is 30 inches tall. Five chairs stacked together are 38 inches tall. How tall in inches will a stack of 10 chairs be?
9	The digits 2, 3, 4, 5 and 9 are used to form the smallest possible five-digit even integer N (each digit is used exactly once). What is the value of $N \bmod 100$ ?
10	If one potato chip weighs $\frac{1}{5}$ of an ounce, how many potato chips would it take to weigh 4.5 pounds?
11	PJ solved the equation $ax^2 + bx + c = 0$ , where a, b, and c are integers that are all relatively prime to each other, and $a > 0$ , and got the solutions: $x = \frac{-7 \pm \sqrt{57}}{4}$ What is the value of $a + b + c$ ?
12	How many four letter sequences can be made from the letters in the word STATISTICS, if letters cannot be repeated? For example, STTA is not a valid sequence.
13	Aditi's first four chemistry lab scores are 72, 81, 85 and 99. All lab scores are integer values from 0 to 100 inclusive. How many possible scores can Aditi get on the 5th lab assignment so that the median of all five lab scores will be exactly 85?

Continued on next page.

14	The function $f(x) = x^3 + x^2 - 46x + 80$ has three x-intercepts, one of which is at (2, 0). The other two x-intercepts are at (A, 0) and (B, 0). What is the value of $A + B$ ?
15	What is 80% of 150% of 25?
16	What is the next term in the sequence that begins: -10, -5, 4, 17, 34, ...
17	One train leaves the station heading due west at an average rate 50 miles per hour. A second train leaves the same station at the same time at an average rate of $50\sqrt{2}$ miles per hour heading northwest, at $45^\circ$ to the first train. In miles, what is the shortest distance between the two trains after 24 minutes?
18	At a math contest, the four finalists are Alge-Bro, Joe-Mom-etry, Math Master G and The Denominator. Their respective probabilities of winning the contest are $\frac{11}{28}$ , $\frac{5}{12}$ , $\frac{3}{28}$ and $\frac{1}{12}$ . The day of the contest, The Denominator sprained his brain and was unable to compete. The new probability for Alge-Bro to win can be written as a reduced common fraction $A/B$ . What is $A + B$ ?
19	Kaylee, Lu, Mayra and Nathan are comparing their heights in centimeters. We know that: <ul style="list-style-type: none"> <li>• Nathan is 3 cm taller than Kaylee</li> <li>• Mayra is 6 cm taller than Lu</li> <li>• Mayra's height is the arithmetic average of Lu's and Nathan's heights</li> </ul> What is the positive difference in height, in centimeters, between the shortest person and the second tallest person?
20	Two full decks of playing cards are combined (standard 52-card decks). What is the fewest number of cards that must be selected to be guaranteed of having at least one four-of-a-kind?
21	The function $g(x)$ is created by transforming the following function $f(x)$ with a horizontal shift of 4 units to the right and a vertical shift of 3 units down. The resulting function $g(x)$ can be written: $g(x) = A(x - B)^2 + C$ , where $A$ , $B$ and $C$ are all non-negative integers. What is $A + B + C$ ? $f(x) = 2(x - 1)^2 + 3$
22	The tenth term in an arithmetic sequence is equal to four times the first term. The sum of the first 10 numbers of the sequence is 450. What is the second term in the sequence?
23	A square has an area of 40 square inches. The length of the diagonal, in inches, can be written as a fully-reduced radical $A\sqrt{B}$ . What is $A + B$ ?
24	Evaluate: $\log(1750_8)$
25	As a reduced common fraction, the mean of the following data set is $A/B$ . What is the value of $A + B$ ? $\left\{ \frac{2}{5}, \frac{5}{3}, \frac{13}{12}, \frac{7}{10} \right\}$

Continued on next page.

26	Mr. Saari made a stem-and-leaf plot of the first test scores from his <i>Geometry</i> students, where the Stem represents the tens digit and the Leaf represents the units digit. Find the value of: $\text{Range} * (\text{Median} - \text{Mode})$	<table border="1"> <thead> <tr> <th>Stem</th> <th>Leaf</th> </tr> </thead> <tbody> <tr> <td>2</td> <td>2 5 6</td> </tr> <tr> <td>3</td> <td>3 5 6 8</td> </tr> <tr> <td>4</td> <td>2 5 5 6 7 7 7 8 8 9</td> </tr> <tr> <td>5</td> <td>2 4 6 8 8</td> </tr> <tr> <td>6</td> <td>5 8 9</td> </tr> <tr> <td>7</td> <td>4 5</td> </tr> <tr> <td>8</td> <td>7</td> </tr> <tr> <td>9</td> <td>9</td> </tr> </tbody> </table>	Stem	Leaf	2	2 5 6	3	3 5 6 8	4	2 5 5 6 7 7 7 8 8 9	5	2 4 6 8 8	6	5 8 9	7	4 5	8	7	9	9
Stem	Leaf																			
2	2 5 6																			
3	3 5 6 8																			
4	2 5 5 6 7 7 7 8 8 9																			
5	2 4 6 8 8																			
6	5 8 9																			
7	4 5																			
8	7																			
9	9																			
27	A triangle with vertices (3, -2), (4, 1) and (-2, 4) is rotated 90° counterclockwise around the origin. What is the sum of all the x-coordinates of the vertices of the new triangle?																			
28	What is the sum of the coefficients of all terms in the remainder (including any constant term) when the polynomial $P(x) = x^5 + 2x^3 - 3$ is divided by the polynomial $x^2 + x - 2$ ?																			
29	Sterling is filling a box with numbered ping-pong balls. He puts in one ball with the number 1, two balls with the number 2, three balls with the number 3, and so on, ending with ten balls with the number 10. He reaches in and pulls out a single ping-pong ball at randomly. The probability that it contains an even number can be written as a reduced fraction $A/B$ . What is $A + B$ ?																			
30	How many pairs of nonnegative integers $x$ and $y$ are solutions to the following equation: $\frac{x}{19} + \frac{y}{95} = 1$																			
<b>Challenge Questions: 3 points each</b>																				
31	Solve for $y$ , given the following infinite expression: $y = \frac{4}{3 + \log_y \left( \frac{4}{3 + \log_y \left( \frac{4}{3 + \log_y (\dots)} \right)} \right)}$																			
32	Mr. Foster has five pairs of socks in his drawer. Each pair consists of two identical socks, and each pair is distinguishable from every other pair. On Monday, he randomly grabs two socks from the drawer and wears them. Without returning those socks to the drawer, he randomly grabs two socks from the drawer on Tuesday. The probability that he gets a matching pair on Tuesday can be written as a reduced common fraction $A/B$ . What is $A + B$ ?																			
33	The expression $(3x - 11)^3$ can be expanded, resulting in a polynomial in the form $ax^3 + bx^2 + cx + d$ . What is the value of $a + b + c + d$ ?																			

Continued on next page.



# "Math Is Cool" Championships - 2022-23

**KEY**

## High School Individual Contest - Answer Key

SCORERS: Bracketed [...] items in answer key are optional. Just mark the score as 0 or 1 and add up those values to reflect total correct.  
First Scorer - use the right-hand columns so 2<sup>nd</sup> scorer can do a blind scoring.

	Answer
1	-4
2	1035
3	540 [cm <sup>3</sup> ]
4	50 [%]
5	5
6	2
7	43
8	48 [inches]
9	94
10	360 [potato chips]
11	8
12	120 [sequences]
13	16 [scores]
14	[A + B =] -3
15	30

	Answer
16	55
17	20 [miles]
18	10
19	9 [cm]
20	40
21	7
22	24
23	9
24	3
25	[A + B =] 157
26	77
27	-3
28	0
29	17
30	20 [pairs]

	Answer
31	1
32	10
33	[a + b + c + d =] -512
34	1
35	2400 [ways]
36	12 [units]
37	936
38	5
39	108
40	65

---

---

---

---

---





# "Math Is Cool" Championships — 2022-23

9/10<sup>th</sup> Grade — October, 2022

## Individual Multiple Choice Contest

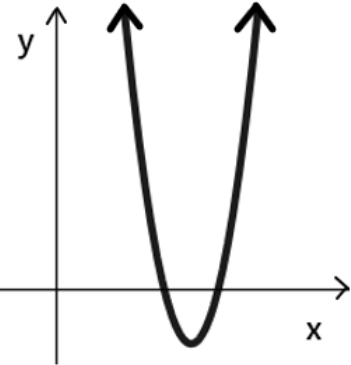
1	<p>Given the following data set, which quantity cannot be changed by adding a single integer to the set? {2, 5, 18, 10, 5, 6, 13, 5}</p> <p>A) Median    B) Mode    C) Mean    D) Range    E) Answer not given.</p>
2	<p>If <math>x = 3 + \sqrt{8}</math>, find the value of: <math>x + \frac{1}{x}</math></p> <p>A) 6    B) <math>2\sqrt{10}</math>    C) <math>3\sqrt{8}</math>    D) <math>2\sqrt{12}</math>    E) Answer not given</p>
3	<p>Mrs. Stephenson has two bags of dice. The first bag has 7 red dice and 6 white dice. The second bag has 4 red dice and 9 white dice. If she chooses one die randomly from each bag, what is the probability that they are both red?</p> <p>A) <math>\frac{7}{13}</math>    B) <math>\frac{11}{13}</math>    C) <math>\frac{11}{169}</math>    D) <math>\frac{4}{257}</math>    E) Answer not given.</p>
4	<p>Which of the following functions could describe the graph shown here?</p>  <p>A) <math>f(x) = (x + 12)^2 + 4</math>    B) <math>f(x) = (8 - x)(12 - x)</math> C) <math>f(x) = (2x + 3)^2 - 5</math>    D) <math>f(x) = 2(-x + 2)(x + 3)</math> E) None of them.</p>
5	<p>A clothing shop sells the same shirt in red, blue or green. All three colors cost the same amount of money to make, but they are sold at different markups. The red shirt is marked up 20%, the blue shirt 25% and the green shirt 10%. During a clearance sale, all shirts were offered at a discount. The red shirts were 35% off, the blue shirts were 40% off, and the green shirts were 30% off. Which of the following is the correct comparison of the final price of each shirt?</p> <p>A) red &lt; blue &lt; green    B) green &lt; red &lt; blue    C) blue &lt; red &lt; green D) blue &lt; green &lt; red    E) Answer not given.</p>

Continued on next page.

6 For the right triangle shown here, what is the length of side 'a' in terms of the angle  $\alpha$ ?

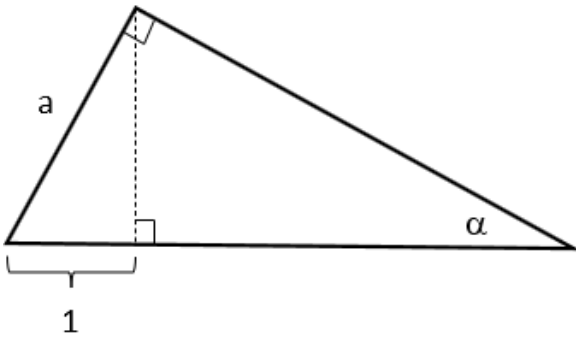

- A)  $a = \sin(\alpha)$     B)  $a = \csc(\alpha)$     C)  $a = \cos(\alpha)$     D)  $a = \sec(\alpha)$     E) Answer not given.

7 Two candles of equal heights but different thicknesses are lit. The first burns off in 8 hours and the second in 10 hours. How long after lighting, in hours, will the first candle be half the height of the second candle? The candles are lit simultaneously and each burns at a constant linear rate.

- A)  $20/3$     B) 6    C)  $43/6$     D)  $49/6$     E) Answer not given.

8 How many two-digit positive integers have the property that the integer is equal in value to the sum of its digits multiplied by 4?

- A) 3    B) 4    C) 5    D) 6    E) Answer not given.

9 A quarter-circle is inscribed in square ABCD as shown below, with its center at vertex D. A smaller circle is tangent to the quarter-circle and to the bottom and left-hand sides of the square and  $\overline{BE}$  is tangent to the smaller circle. What is the number of degrees in the measure of  $\angle BED$ ?

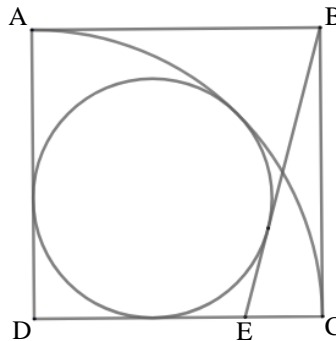

- A)  $95^\circ$     B)  $100^\circ$     C)  $105^\circ$     D)  $120^\circ$     E) Answer not given.

10 Let a sequence be defined as follows:  
 $R_1 = 1, R_2 = 1, R_n$  equals the remainder when  $R_{n-1} + R_{n-2}$  is divided by 5, for  $n \geq 3$ . What is  $R_{2022}$ ?

- A) 0    B) 1    C) 2    D) 3    E) 4

# "Math Is Cool" Championships — 2022-23

9/10<sup>th</sup> Grade — October, 2022

**Key**

## Individual Multiple Choice Contest - Answer Key

### 9/10<sup>th</sup> Grade

Correct responses are worth 2 points, incorrect responses are worth -1 point, and absence of a response is worth 0 points.

	Answer
1	B
2	A
3	E (28/169)
4	B
5	D
6	B
7	A
8	B
9	C
10	B

# "Math Is Cool" Championships — 2022-23

9/10<sup>th</sup> Grade — October, 2022

Final Score (out of 20)

Room #

School Name

Student Name

Team #

## Individ. Multiple Choice Contest - 15 minutes - ~20% of team score

*This test is taken individually, but it is part of your team score, which will be calculated by taking the mean of the top 3 scores from your team. This test is the only test where you will be penalized for incorrect responses. You will receive two points for a correct letter response, zero points for leaving it blank, and minus one point for an incorrect response. When you are prompted to begin, tear off the colored answer sheet and begin testing. ONLY a letter response should be listed as an answer on this answer sheet.*

**Correct responses are worth 2 points, incorrect responses are worth -1 point, and absence of a response is worth 0 points.**

**STUDENTS: DO NOT WRITE IN SHADED REGIONS**

		Scorer 2	Scorer 1
Answer		-1, 0, or 2	-1, 0, or 2
1			
2			
3			
4			
5			
6			
7			
8			
9			
10			
<b>9/10<sup>th</sup> Grade</b>		<b>TOTAL:</b>	

# "Math Is Cool" Championships — 2022-23

9/10<sup>th</sup> Grade — October, 2022

## Team Contest

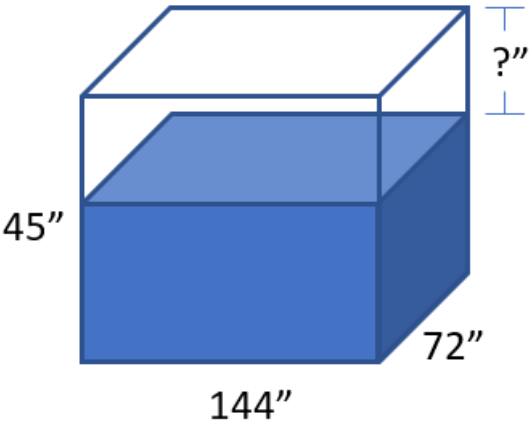
1	Solve for $x$ : $4 - 2(2 - 3x) - 6 = 9 + 2(5x - 4.5) - 10x$
2	On the coordinate plane, the point $(3, 7)$ is rotated counterclockwise $90^\circ$ about the origin to a new location with coordinates $(a, b)$ . What is the value of $a + b$ ?
3	The distance around the Earth is approximately $4 \times 10^4$ km. The distance from the Earth to the Moon is approximately $4 \times 10^5$ km. Approximately how many trips around Earth is equivalent to a round-trip visit to the Moon?
4	The set of integers shown below have the same median and mode. What is the value of $n$ ? $\{47, 91, 39, 20, 83, n\}$
5	<p>A bin in the shape of a rectangular prism is 144 inches long, 72 inches wide and 45 inches tall, as shown below. When the bin contains exactly 8 cubic yards of water, how many inches are in the distance between the top edge of the bin and the top surface of the water? Note: the diagram is not to scale.</p> 
6	PumpCo has many identical pumps to remove water after a flood. Multiple pumps are being used to remove water from a flooded basement. With the number of pumps being used, it will take 10 hours to remove the water. If 2 additional pumps had been used, it would only take 8 hours. How many hours would it take one pump to remove the water?
7	Nikhar has a one-dollar bill, a five-dollar bill, and a ten-dollar bill and Devanshi has a one-, a five-, a ten-, and a twenty-dollar bill. If the two randomly exchange one bill, the probability as a reduced common fraction that Devanshi has the same amount of money as Nikhar is $A/B$ . What is the value of $A + B$ ?

Continued on next page.

8 The circle shown here has twelve equal sections. Each section will contain a different integer from 1 to 10, and the remaining two sections will contain stars. Use the statements below to determine the layout of the numbers.

What is the sum of the numbers in the four sections that are immediately adjacent to the stars?

1. The five even numbers appear in order counterclockwise, though not necessarily in consecutive sections.
2. The numbers 1 and 3 are adjacent to the section that is directly opposite from the number 2. The number 7 is directly between two sections with numbers totaling 7.
3. Two numbers are adjacent to, in a clockwise direction, their respective square roots (if the number is in one section, move clockwise to get to its square root).
4. No two adjacent sections have numbers totaling more than 12.

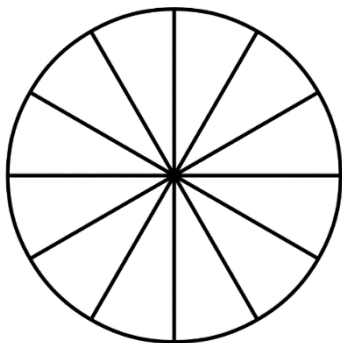

9 Let  $i = \sqrt{-1}$ ,  $a + b = 15$ , and  $ab = 54 - 64i$ . If  $a^2 + b^2 = c + di$ , for real  $c$  and  $d$ , then what is  $c - d$ ?

10 Let  $a$ ,  $b$ , and  $c$  be three distinct integer bases, such that:

$$12_a + 54_b = 31_c \text{ and } 23_a + 8_b = 16_c$$

where, for example,  $12_a$  indicates 12 base  $a$ .

What is the minimum possible sum  $a + b + c$ ?

# "Math Is Cool" Championships — 2022-23

9/10<sup>th</sup> Grade — October, 2022

**Key**

## Team Contest - Answer Key

### 9/10<sup>th</sup> Grade

Answer	
1	1
2	-4
3	20
4	47
5	9 [inches]
6	80 [hours]
7	13
8	29
9	-11
10	35



# "Math Is Cool" Championships — 2022-23

9/10<sup>th</sup> Grade — October, 2022

Final Score (out of 10)

Room #

School Name

Team #

## Team Contest - 15 minutes - ~30% of team score

When you are prompted to begin, tear off the colored answer sheet and give a copy of the test to each of your team members and begin testing. Each problem is scored as a 1 or 0. Record all answers on this colored answer sheet.

STUDENTS: DO NOT WRITE IN SHADED REGIONS

Answer		Scorer 2	Scorer 1
		0 or 1	0 or 1
1			
2			
3			
4			
5			
6			
7			
8			
9			
10			
<b>9/10<sup>th</sup> Grade</b>		<b>TOTAL:</b>	

# "Math Is Cool" Championships — 2022-23

9/10<sup>th</sup> Grade — October, 2022

## Pressure Round Contest

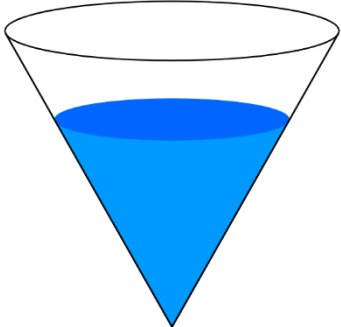
1	<p>A 20 foot tall cone that was full of water has now been partially drained. The water level is now 5 feet from the top of the cone in the vertical direction. The ratio of the volume of water remaining in the cone to the original volume of water can be written as a reduced common fraction <math>A/B</math>. What is <math>A + B</math>?</p>	
2	<p>Solve for <math>x</math>:</p> $\frac{3}{2} - \frac{7}{x-1} = \frac{5}{2}$	
3	<p>A game is played as follows. There are 8 boxes on a table, 4 of which contain a golden coin. The other 4 contain nothing. A contestant wins if they get at least 2 golden coins. The contestant randomly selects 4 of the boxes. The probability that the contestant wins the game can be written as a reduced fraction <math>A/B</math>. What is <math>A + B</math>?</p>	
4	<p>A palindrome is a number that reads the same forwards and backwards. How many three-digit palindromes are there in which the units digit is a factor of the middle digit?</p>	
5	<p>On the graph of the line <math>2x - 3y = 12</math>, how many grid points (where the <math>x</math>- and <math>y</math>-coordinates are both integers) are on the portion of the line that lies in Quadrant IV?</p>	

# "Math Is Cool" Championships — 2022-23

## 9/10<sup>th</sup> Grade — October, 2022

Final Score <i>(out of 5)</i>
-------------------------------

Room #	School Name	Team #
--------	-------------	--------

### Pressure Round Score Sheet

Submittal # <small>(order turned in)</small>	<b>1</b>	<b>2</b>	<b>3</b>	<b>4</b>	<b>5</b>
Question #					
Score <small>(circle value)</small>	0 or 1	0 or 2	0 or 3	0 or 4	0 or 5
Scoring Room <small>(checkmark)</small>					

Team: Fill in the room, school, and Team #, then hand only this sheet to the Proctor.  
 Proctor: staple this to the top of the five submittals in order.

# "Math Is Cool" Championships — 2022-23

## 9/10<sup>th</sup> Grade — October, 2022

Final Score <i>(out of 5)</i>
-------------------------------

Room #	School Name	Team #
--------	-------------	--------

### Pressure Round Score Sheet

Submittal # <small>(order turned in)</small>	<b>1</b>	<b>2</b>	<b>3</b>	<b>4</b>	<b>5</b>
Question #					
Score <small>(circle value)</small>	0 or 1	0 or 2	0 or 3	0 or 4	0 or 5
Scoring Room <small>(checkmark)</small>					

Team: Fill in the room, school, and Team #, then hand only this sheet to the Proctor.  
 Proctor: staple this to the top of the five submittals in order.

# "Math Is Cool" Championships — 2022-23

9/10<sup>th</sup> Grade — October, 2022

Room #

School Name

Team #

## Pressure Round Answer Submittal

Submittal #	for Question #	Answer
<b>1</b> (at 2 minute mark)		

Team: Fill in the room, school, and Team # before the round starts.

Write the question number being answered and the associated answer (or a blank).

You may answer questions in any order. A question may not be answered more than once.

# "Math Is Cool" Championships — 2022-23

9/10<sup>th</sup> Grade — October, 2022

Room #

School Name

Team #

## Pressure Round Answer Submittal

Submittal #	for Question #	Answer
<b>1</b> (at 2 minute mark)		

Team: Fill in the room, school, and Team # before the round starts.

Write the question number being answered and the associated answer (or a blank).

You may answer questions in any order. A question may not be answered more than once.

# "Math Is Cool" Championships — 2022-23

9/10<sup>th</sup> Grade — October, 2022

Room #

School Name

Team #

## Pressure Round Answer Submittal

Submittal #	for Question #	Answer
<b>2</b> (at 4 minute mark)		

Team: Fill in the room, school, and Team # before the round starts.

Write the question number being answered and the associated answer (or a blank).

You may answer questions in any order. A question may not be answered more than once.

# "Math Is Cool" Championships — 2022-23

9/10<sup>th</sup> Grade — October, 2022

Room #

School Name

Team #

## Pressure Round Answer Submittal

Submittal #	for Question #	Answer
<b>2</b> (at 4 minute mark)		

Team: Fill in the room, school, and Team # before the round starts.

Write the question number being answered and the associated answer (or a blank).

You may answer questions in any order. A question may not be answered more than once.

# "Math Is Cool" Championships — 2022-23

9/10<sup>th</sup> Grade — October, 2022

Room #

School Name

Team #

## Pressure Round Answer Submittal

Submittal #	for Question #	Answer
<b>3</b> (at 6 minute mark)		

Team: Fill in the room, school, and Team # before the round starts.

Write the question number being answered and the associated answer (or a blank).

You may answer questions in any order. A question may not be answered more than once.

# "Math Is Cool" Championships — 2022-23

9/10<sup>th</sup> Grade — October, 2022

Room #

School Name

Team #

## Pressure Round Answer Submittal

Submittal #	for Question #	Answer
<b>3</b> (at 6 minute mark)		

Team: Fill in the room, school, and Team # before the round starts.

Write the question number being answered and the associated answer (or a blank).

You may answer questions in any order. A question may not be answered more than once.

# "Math Is Cool" Championships — 2022-23

9/10<sup>th</sup> Grade — October, 2022

Room #

School Name

Team #

## Pressure Round Answer Submittal

Submittal #	for Question #	Answer
<b>4</b> (at 8 minute mark)		

Team: Fill in the room, school, and Team # before the round starts.

Write the question number being answered and the associated answer (or a blank).

You may answer questions in any order. A question may not be answered more than once.

# "Math Is Cool" Championships — 2022-23

9/10<sup>th</sup> Grade — October, 2022

Room #

School Name

Team #

## Pressure Round Answer Submittal

Submittal #	for Question #	Answer
<b>4</b> (at 8 minute mark)		

Team: Fill in the room, school, and Team # before the round starts.

Write the question number being answered and the associated answer (or a blank).

You may answer questions in any order. A question may not be answered more than once.

# "Math Is Cool" Championships — 2022-23

9/10<sup>th</sup> Grade — October, 2022

---

Room #

---

School Name

---

Team #

## Pressure Round Answer Submittal

<b>Submittal #</b>	<b>for Question #</b>	<b>Answer</b>
<b>5</b> (at 10 minute mark)		

Team: Fill in the room, school, and Team # before the round starts.

Write the question number being answered and the associated answer (or a blank).

You may answer questions in any order. A question may not be answered more than once.

# "Math Is Cool" Championships — 2022-23

9/10<sup>th</sup> Grade — October, 2022

---

Room #

---

School Name

---

Team #

## Pressure Round Answer Submittal

<b>Submittal #</b>	<b>for Question #</b>	<b>Answer</b>
<b>5</b> (at 10 minute mark)		

Team: Fill in the room, school, and Team # before the round starts.

Write the question number being answered and the associated answer (or a blank).

You may answer questions in any order. A question may not be answered more than once.



# "Math Is Cool" Championships — 2022-23

9/10<sup>th</sup> Grade — October, 2022

Room #

School Name

Team #

## Total Score for Each Round

College Bowl #1 (10 Possible)	College Bowl #2 (10 Possible)	College Bowl #3 (10 Possible)

DO NOT USE TALLY MARKS ON THIS SHEET. WRITE THE TOTAL SCORE FOR EACH ROUND.

# "Math Is Cool" Championships — 2022-23

9/10<sup>th</sup> Grade — October, 2022

Room #

School Name

Team #

## Total Score for Each Round

College Bowl #1 (10 Possible)	College Bowl #2 (10 Possible)	College Bowl #3 (10 Possible)

DO NOT USE TALLY MARKS ON THIS SHEET. WRITE THE TOTAL SCORE FOR EACH ROUND.

# "Math Is Cool" Championships — 2022-23

9/10<sup>th</sup> Grade — October, 2022

Proctor  
Copy

## Mental Math Contest

**MENTAL MATH** - 30 seconds per question - ~25% of team score & ~8% of individual score

All students in the room will concurrently be asked the same eight questions in this individual test. When it is time to begin, the proctor will read the first question twice. You may not do any writing or talking while arriving at a solution. Once you have a solution, record it on the sheet in front of you. **You may not change or cross out answers once you have written an answer down. If there are eraser marks, write-overs, or crossed-out answers, they will be marked wrong.** Once all students have laid their pencils on the desk, another question will be asked. If a student doesn't lay his or her pencil down, the maximum wait time is 30 seconds after completion of the second reading of the question before the next question is read. You may continue to work on a problem (in your head) while the next question is being read. The raw score is 1 point per correct answer.

1	Due to inflation, the owners of Hill's Bait shop raised the prices of their nightcrawlers by 10% in July. In August, they raised the prices by an additional 20%. What was the overall increase in percent?	
2	In the equation $3^x = 1000$ (read as: 3 raised to the x equals 1000), the value of x that makes the equation true lies between two consecutive integers A and B. What is A + B?	
3	What is the y-coordinate of the vertex of the parabola described by the function: $f(x) = x^2 - 10x + 1$ (read as: x-squared minus 10x plus 1)	
4	What is the sum, in units, of the lengths of all of the edges of a rectangular prism that measures 4 units wide by 7 units tall by 9 units deep.	
5	An arithmetic sequence has a common difference of 4. The sum of the first two terms in the sequence is 10. What is the value of the 4 <sup>th</sup> term in the sequence?	
6	Two cards are randomly selected from a standard deck of playing cards, with replacement. The probability that one of them is a heart and one of them is a diamond can be written as a reduced common fraction A/B (read as: A over B). What is A + B?	
7	A farmer was counting his cows. The first herd was consecutively numbered 45 through 83. The second herd was consecutively numbered 191 through 213, except cow number 211 was missing. How many total cows were there?	
8	Expressed as a base 10 number, what is the largest 4 digit base 5 number? Do not include the base 10 in your answer.	

# "Math Is Cool" Championships — 2022-23

9/10<sup>th</sup> Grade — October, 2022

**Key**

## Pressure Round Contest - Answer Key

### 9/10<sup>th</sup> Grade

Answer	
1	91
2	-6
3	123
4	23 [palindromes]
5	1 [point]

# "Math Is Cool" Championships — 2022-23

9/10<sup>th</sup> Grade — October, 2022

Key

## COLLEGE BOWL ROUND #1

#	Problem	Answer
1	How many minutes are there in 30% of one day?	432 [minutes]
2	Micah has a 12 foot long by 8 foot wide by 8 foot tall box. What is the maximum number of 2 foot by 2 foot by 4 foot blocks that can fit inside the box?	48 [blocks]
3	Gregg plans to build a fence to enclose his hamster pasture. The pasture is square with a perimeter of 96 feet, and he sets fence posts at each corner, with additional posts at regular 6-foot intervals. How many posts will he need?	16 [posts]
4	A coin is flipped three times and a fair 6-sided die is rolled once. The probability that the coin turns up heads all three times and the die rolls a 2 can be written as a reduced common fraction $A/B$ (read: A over B). What is $A + B$ ?	49
5	The Greatest Common Factor for a pair of numbers is 18, and their Least Common Multiple is 180. If one of the numbers is 90, what is the other number?	36
6	What is the sum of the first 10 terms of the sequence that starts with index $n = 1$ and has a general term $a_n$ (read: a-sub-n) equal to $3n - 2$ ?	145
7	The number 77 is written as the sum of two numbers. One of the numbers is 5 more than three times the other number. What is the larger of the two numbers?	59
8	How many scalene triangles with integral side lengths have a perimeter equal to 12 units?	1 [triangle]
9	What is the median of the set of integers from 6 through 100, inclusive?	53
10	The 'digit sum' of a whole number is the sum of its individual digits. For example, the digit sum of 123 is 6, because $1+2+3 = 6$ . How many positive 3-digit whole numbers have a digit sum of 4?	10 [whole numbers]

# "Math Is Cool" Championships — 2022-23

9/10<sup>th</sup> Grade — October, 2022

Key

## COLLEGE BOWL ROUND #2

#	Problem	Answer
1	The mean of 8 numbers is 100. If seven is added to each of the numbers, what is the new mean of the 8 numbers?	107
2	Given that a prime number is less than 37, the probability that it is less than 23 can be written as a reduced common fraction $A$ over $B$ (read: $A$ over $B$ ). What is $A + B$ ?	19
3	How many distinct prime factors does the number 32340 (read: thirty-two thousand three hundred forty) have?	5
4	The Incredible Hulk can double the distance he jumps with each succeeding jump. If his first jump is 1 meter, the second jump is 2 meters, the third jump is 4 meters, and so on, on which jump number will he first be able to jump more than 1 kilometer in a single jump?	11
5	On a 26-question math test, 5 points were deducted for each wrong answer, and 8 points were awarded for each correct answer. If all questions were answered, and the final score was 0, how many questions were answered correctly?	10 [questions]
6	Aidan and Ruby are playing tic-tac-toe. Wins are worth 1 point, ties are worth half a point and losses are worth 0 points. In how many different orders of wins, losses and ties can Ruby get 3 points in the first four games?	10 [orders]
7	How many points in a plane are 1 cm away from a given line segment that is 4 cm long, and are also 2 cm away from the midpoint of the segment?	4 [points]
8	Hannah writes down all of the integers from 1 to 3110 (read: three thousand one hundred and ten), inclusive. How many total digits did Hannah write?	11333 [digits]
9	Arrange the digits 1, 3, 9, 0 and 6 to form the greatest 5-digit number that is divisible by 4.	93160
10	How many ways are there to hang 2 identical red shirts, 2 identical blue shirts and 2 identical white shirts in a closet?	90 [ways]

# "Math Is Cool" Championships — 2022-23

9/10<sup>th</sup> Grade — October, 2022

Key

## COLLEGE BOWL ROUND #3

#	Problem	Answer
1	What is the mean of the positive odd integers from 1 through 99, inclusive?	50
2	Jaxon bought 12 mangoes and 12 lemons. He can get 8 ounces of mango juice from 3 mangoes and 8 ounces of lemon juice from 2 lemons. He makes a juice blend from an equal number of mangoes and lemons. What percent of the juice blend is mango juice?	40 [%]
3	Consider the function $f(x) = 3x^2 - 5$ (read: 3 x-squared minus 5). Find the value of $f(1) + f(2)$ (read: f of 1 plus f of 2).	5
4	LeBron ate 100 cookies in five days. On each day, he ate 6 more than on the previous day. How many cookies did he eat on the fifth day?	32
5	Biff and Eho play a game involving a circle whose circumference is divided by 12 equally spaced points. The points are numbered clockwise, from 1 to 12. They both start on point 12. In one turn, Biff moves 5 points clockwise and Eho moves 9 points counterclockwise. How many turns will it take until they are on the same point again?	6 [turns]
6	A rhombus has diagonals of lengths 12 centimeters and 16 centimeters. What is the perimeter of the rhombus in centimeters?	40 [cm]
7	Twenty workers completed one-fourth of a job in 8 days. Working at the same rate, how many additional workers will be needed to complete the job in the next 5 days.	76 [workers]
8	In a bag with 20 marbles, five of them are blue. How many blue marbles must be added to the bag so that the probability of selecting a blue marble at random is $\frac{1}{2}$ ?	10
9	How many minutes are there between 9:23 and 0 seconds AM and 2:12 and 0 seconds PM on the same day?	289 [minutes]
10	What is the sum of the three consecutive integers whose product is 336?	21

# "Math Is Cool" Championships — 2022-23

9/10<sup>th</sup> Grade — October, 2022

Key

## COLLEGE BOWL ROUND #4

#	Problem	Answer
1	Let $f(x) = \sqrt{x}$ (read: f of x equal the square root of x) and $g(x) = x^2 + 9$ (read: g of x equal x-squared plus 9). Find the value of $f(g(4))$ (read: f of g of 4).	5
2	Hunter ordered a pizza on January 1 <sup>st</sup> . On January 1 <sup>st</sup> he ate half of the pizza. For the next five days, each day he ate half of the remaining pizza. After eating his allotted pizza on January 6 <sup>th</sup> , the remaining fraction of the pizza can be written as a reduced common fraction $A/B$ (read: A over B). What is $A + B$ ?	65
3	When two fair six-sided dice are rolled, what is the probability in percent that the largest number rolled, not necessarily distinct, is a 5?	25 [%]
4	Casey travels from point A to point B at a rate of 2 minutes per mile, and returns over the same route at 2 miles per minute. What was their average speed in miles per hour for the whole trip?	48 [miles per hour]
5	If $x$ plus $y = 6$ and $x$ times $y = 2$ , what is the value of $1$ over $x$ -squared + $1$ over $y$ -squared?	8
6	There are 24 arrangements of the four letters M, A, T, H. If the arrangements are put into alphabetical order and numbered from 1 to 24, in what position is the arrangement MATH, spelled M-A-T-H?	14
7	ABCD is a quadrilateral with right angles at B and D. The length of segment $AB = 7$ units, $BC = 24$ units, $CD = 20$ units and $DA = 15$ units. What is the area of the quadrilateral in square units?	234 [square units]
8	On a Statistics exam, 10% of the students got 70 points, 25% got 80 points, 20% got 85 points, 15% got 90 points, and the rest got 95 points. What is the median score for this exam in points?	85 [points]
9	What is the thirteenth prime number?	41
10	What is the slope of the line $12x/3y = 2$ (read: 12x over 3y equals 2)?	2

# "Math Is Cool" Championships — 2022-23

9/10<sup>th</sup> Grade — October, 2022

Key

## COLLEGE BOWL ROUND #5

#	Problem	Answer
1	How many distinct factors does the number $12^8$ (read: 12 to the 8 <sup>th</sup> ) have?	153
2	The sum of the first nine terms of an arithmetic sequence is 45. What is the fifth term of the arithmetic sequence?	5
3	A regular hexagon has side length 2 inches. The area of the hexagon in square inches can be written as $A$ times the square root of $B$ . What is $A + B$ ?	9
4	The domain of the function $f(x) = \sqrt{-x^2 - 2x + 3}$ (read: $f$ of $x$ equals the square root of the quantity negative $x$ -squared minus $2x + 3$ ) is the set of real numbers $x$ such that $A \leq x \leq B$ (read: $A$ is less than or equal to $x$ is less than or equal to $B$ ), where $A$ and $B$ are integers. What is the value of $A + B$ ?	-2
5	Four distinct girls and 3 distinct boys randomly line up in a row. The probability that nobody is standing next to someone of the same gender can be written as a reduced common fraction $A/B$ (read: $A$ over $B$ ). What is $A + B$ ?	36
6	What is 10 times the log base 4 of 32?	25
7	If 6 factorial times 7 factorial equals $N$ factorial, what is the value of $N$ ?	10
8	If $x + y = 8$ , $y + z = 3$ , and $x + z = 1$ , what is the value of $x$ ?	3
9	In a bag of marbles, two-fifths of the marbles are red, three-tenths of the marbles are white, and one-tenth of the marbles are blue. The remaining 10 marbles are green. How many total marbles are in the bag?	50 [marbles]
10	Square $S_1$ has an area of 16 square units. Each side of square $S_1$ is bisected, and a smaller square $S_2$ is constructed using the bisection points as vertices. Each side of square $S_2$ is bisected, and a smaller square $S_3$ is constructed using the bisection points as vertices. What is the area of square $S_3$ in square units?	4 [square units]



# "Math Is Cool" Championships — 2022-23

9/10<sup>th</sup> Grade — October, 2022

Key

## COLLEGE BOWL ROUND #6

#	Problem	Answer
1	A geometric sequence has 2 <sup>nd</sup> term 20 and 10 <sup>th</sup> term 350. What is the product of the first term and the common ratio $r$ ?	20
2	What value of $x$ will give the maximum function value for $f(x) = -6x^2 + 12x + 7$ (read: negative six $x$ -squared plus 12 $x$ plus 7)?	1
3	A regular polygon has interior angles measuring $179^\circ$ each, and a side length of 3 cm. What is the perimeter of the polygon in centimeters?	1080 [cm]
4	How many divisors of 1000 are also multiples of 4?	8 [divisors]
5	Hershey the dog has to climb a flight of six stairs to get to his favorite sleeping spot. He can take the stairs 1, 2, or 3 at a time. For example, he could climb 2, then 3, then 1. In how many different ways can Hershey climb the 6 stairs?	24
6	Four integers are added to the set $\{3, 4, 5, 5, 8\}$ , increasing the mean, median and mode each by 1. What is the greatest integer in the new set?	11
7	Alyssa can mow a lawn in 50 minutes. Working together, Alyssa and Jenny can mow the same lawn in 30 minutes. How many minutes would it take Jenny to mow the lawn alone?	75 [minutes]
8	Carlos rolls three 6-sided dice. The probability that all three of the dice show the same number can be written as a reduced common fraction $A/B$ (read: $A$ over $B$ ). What is $A + B$ ?	37
9	A 12-foot long piece of lumber is cut into two pieces with lengths in a ratio of 1:3 (read: 1 to 3). How long is the longer piece, in inches?	108 [inches]
10	80 times 10 to the 4 <sup>th</sup> divided by 0.4 times 10 to the -9 equals 2 times 10 to the $n$ th power. What is $n$ ?	15

# "Math Is Cool" Championships — 2022-23

9/10<sup>th</sup> Grade — October, 2022

**Key**

## COLLEGE BOWL — EXTRA Questions

#	Problem	Answer
1	All terms of an arithmetic sequence are integers. If the first term is 10, the last term is 74 and the sequence has $n$ terms, what is the median of all possible values of the common difference, $d$ ?	8
2	If $4x + 14 = 6(x - 2)$ (read: $4x$ plus 14 equals 6 times the quantity $x$ minus 2), what is the value of $x$ ?	13
3	A cube with 3 cm edges is made from 27 cubes with 1 cm edges. 23 of the cubes are red, and 4 of the cubes are yellow. If all 4 yellow cubes are used on corners of the new larger cube, the fraction of the surface area of the new cube that is yellow can be written as a reduced common fraction $A/B$ (read: $A$ over $B$ ). What is $A + B$ ?	11
4	If 17 people attend a meeting, and each person shakes hands with every other person exactly one time, how many total handshakes take place?	136 [handshakes]
5	If the length of a rectangle is increased by 20% and its width is increased by 40%, then by what percent is the area of the rectangle increased?	68 [%]
6	Eileen has a 10% chance of being accepted into MIT, and a 20% chance of being accepted into Harvard. What is the probability in percent that she gets accepted into both schools?	2 [%]

# Proctoring Overview

You will receive a room packet envelope with the schedule and College Bowl rotations on the front. Each room packet includes:

- 1) the proctor instructions and the general instructions that you will be reading,
- 2) the proctor question/answers packet (this needs to be carefully controlled), and
- 3) sets of Mental Math, Individual, Multiple Choice, Team, and Pressure Round tests. (If not in the room packet, the proctor supervisor will provide blank scratch paper.)

When you receive the room packet, count to ensure that you have the correct number of tests for each event (16 Mental Math & Individual, 4 of each of the team events).

## Key Points

- Act professional; focus on what you are doing.
- Your job is to proctor the students; that is, you administer tests, give time warnings, & monitor students for proper test taking behavior to ensure competition integrity and avoid issues like failing to put answers on the answer sheet.
- The proctor packet has Mental Math, Pressure Round, and College Bowl questions/answers. Keep the packet secure! Avoid opportunities for competitors to see tests or answers.
- Student/school names and team numbers are critical on the answer sheets. Make sure that students fill out such identifying information.
- Keep track of time, and provide appropriate time warnings. Keep to the schedule as close as possible. Wait between events, if needed.
- Read & know the rules—competitors & spectators will, and they will call you on it.
- On questions that you read, read smoothly, enunciate clearly, and don't read too fast.
- If unsure of how to deal with an issue/question/concern, flag down the proctor supervisor and ask.
- Be respectful of your classroom — leave it tidy and arranged exactly as you found it. We don't want any displeased teachers!!
- Use the quick-reference guide on the next page for room setup and key information.

## Schedule

*Each of the 6 events includes about 5 minutes at the start for reading instructions or rearranging the room.*

3:30 - 4:00	Coaches register (Library)	6:10 - 6:40	Proctors get dinner in proctor room
4:05 - 4:15	Orientation (Gym)	6:45 - 6:55	College Bowl #1
4:15 - 4:20	Students go to testing rooms	6:55 - 7:05	College Bowl #2
4:20 - 4:35	Mental Math	7:05 - 7:15	College Bowl #3
4:35 - 5:15	Individual Test	7:15 - 7:25	College Bowl #4
5:15 - 5:35	Individual M.C. Test	7:25 - 7:35	College Bowl #5
5:35 - 5:55	Team Test	7:35 - 7:45	College Bowl #6
5:55 - 6:10	Pressure Round	8:00 - 8:30	Awards Ceremony (Gym)

### 1. Mental Math

**Configuration:** Students at individual desks spread out in the classroom. Alternating desks, students not next to teammates.

**Scheduled Time:** 4:20-4:35 PM (read instructions & test)

**Duration:** 30 seconds per question maximum (beginning after the 2<sup>nd</sup> reading)

**Give Time warning at:** 5 seconds

**Number of questions:** 8 (all students do the same questions)

**Proctor Actions:** Read each question twice, reading clearly and not too fast. Start the 30 second clock after the 2<sup>nd</sup> reading.

**Key Points:** Start by reading "General Instructions" then Mental Math instructions. Make sure everyone writes their name, school & team number on the answer sheet. No talking allowed. Except for the answer, no writing allowed. Collect answer sheets and organize by team number, then alphabetically by first name of competitor, & staple sheets for the same team together.

### 2. Individual Test

**Configuration:** Students at individual desks; same arrangement as for Mental Math.

**Scheduled Time:** 4:35 PM (read instructions),  
4:40-5:15 (test)

**Duration:** 35 minutes

**Give Time warning at:** 5 minutes & 30 seconds

**Number of questions:** 40

**Proctor Actions:** Ensure appropriate test-taking behavior. Prep for next event (or read College Bowl questions to yourself).

**Key Points:** Read "Individual Test" instructions. Make sure everyone writes their name, team number, school, proctor name, & room number down on the answer sheet. Collect answer sheets, organize by team, then alphabetically by first name of competitor, and staple sheets for same team together.

### 3. Individual Multiple Choice Test

**Configuration:** Students at individual desks; same arrangement as for the Individ. Test.

**Scheduled Time:** 5:15 PM (read instructions),  
5:20-5:35 PM (test)

**Duration:** 15 minutes

**Give Time warning at:** 5 minutes & 30 seconds

**Number of questions:** 10

**Proctor Actions:** Ensure appropriate test-taking behavior. Prepare for next event.

**Key Points:** Read Multiple Choice instructions. This is an individual test.

### 4. Team Test

**Configuration:** Groups of 4 desks, with the groups spread out in the classroom.

**Scheduled Time:** 5:35 PM (read instructions),  
5:40-5:55 PM (test)

**Duration:** 15 minutes

**Give Time warning at:** 5 minutes & 30 seconds

**Number of questions:** 10

**Proctor Actions:** Ensure appropriate test-taking behavior. Prepare for next event.

**Key Points:** Read Team Test instructions. Need to have school & team number on answer sheet. Students can talk quietly & work together.

### 5. Pressure Round

**Configuration:** Groups of 4 desks spread out in the classroom (same as Team Test).

**Scheduled Time:** 5:55 PM (read instructions),  
6:00-6:10 PM (test)

**Duration:** 10 minutes (2 minutes per question)

**Give Time warning at:** 5 seconds before end of each 2-minutes

**Number of questions:** 5 (can submit answers in any order)

**Proctor Actions:** Ensure appropriate test-taking behavior. Score submittals as you go (without showing any answers to students).

**Key Points:** Students can talk quietly & work together. Proctor: keep answer sheets in order of submittal; make sure that you score the right question and give the right point value.

### 6. College Bowl

**Configuration:** Row of 9 desks (side by side) at the front of the room (CBA device on center desk).

**Scheduled Time:** 6:45 PM (read instructions),  
6:50-7:45 PM (test)

**Duration:** 45 seconds per question (30 seconds per question if there is only one team, who will be only going against the clock)

**Give Time warning at:** 5 seconds

**Number of questions:** 10 per round, 6 rounds total

**Proctor Actions:** Read each question twice, reading clearly and not too fast. Start 45 (or 30) second clock after the 2<sup>nd</sup> full reading. Mark tally on white board as questions are answered and transfer the numeric total to the score sheets.

**Key Points:** Event is collaborative, talking is allowed. For a wrong answer, just say, "That is incorrect." (no verbal/visual clues that could be interpreted by the other team to arrive at an answer).

# Summary of MIC Proctoring

(for proctors to read to themselves)

Pass out materials (answer sheet/test packets, scratch paper) for the current event to individuals or teams (as appropriate) so they can fill in the name, school, and team number information (very important!). Tell students to not lift the cover sheet or turn over the paper until you give the signal to start. Read the general instructions as the first item at the beginning of the competition (before Mental Math). Read the event-specific instructions just prior to each event and ask if there are any relevant questions. After reading the instructions, you can signal students to begin. Make sure one proctor is watching the time and giving appropriate time warnings (e.g., "five minutes remaining"). At the end of the event, tell competitors to stop work. Collect, sort, & staple the answer sheets (as appropriate) and keep them secure until handed off to a runner.

For the Mental Math/Individual tests, arrange students scattered throughout the classroom with **no student next to another student from their own school**. For the team tests, students will be in groups of 4 desks. College Bowl will require a line of 9 desks side-by-side across the front of the classroom.

For College Bowl, place the College Bowl apparatus (CBA) on a central desk in the line of desks at the front (4 desks on either side of the central one). One proctor will likely need to hold the CBA in place during the College Bowl rounds. Turn the apparatus on by depressing the button or flipping the dip switch. Students may try out the CBA prior to the 1<sup>st</sup> question. Note: while one light is blinking, the other light is locked out. There is no need to "reset" the device, just let the light finish blinking and it is ready to go.

Keep Pressure Round answers secure while you score the submittals because answers for all questions are on the same sheet. Do not read the answer for College Bowl when you read the question (they are both on the same page). In College Bowl, if an incorrect answer is given, simply say "That is incorrect" and do not give any other cues about the answer (e.g., don't say "sorry, you were close" or exhibit interpretable body language). If both teams fail to supply a correct answer, announce what the correct answer was.

If there is an irregularity (i.e., lack of honesty, poor sportsmanship), make a note of the circumstances, flag the answer sheet, and report the issue to the proctor supervisor.

At the end of the day, return the desks to their original arrangement, recycle any unwanted test materials & used scratch paper, erase any marks you made on the whiteboard, and generally make sure the classroom is tidied up. Return the CBA, the room packet envelope, the proctor instructions, the contest rules packet, the proctor packet of questions, extra scratch paper, and unused test material to the proctor supervisor.

# Detailed Instructions for Proctors

## Grades 9-12

NO CALCULATORS ALLOWED ON ANY TESTS!

1. Check to make sure you have everything in your packet.
  - A. **Mental Math:**
    1. 16 - colored Mental Math answer sheets
    2. Mental Math questions with answers (in the Proctor Packet)
  - B. **Individual Test:** 16 individual tests, with colored answer sheets attached
  - C. **Individual Multiple Choice Test:** 16 individual multiple choice packets (stapled), with a colored answer sheet on top
  - D. **Team Test:** 4 team test packets (stapled), each containing 4 tests plus one colored answer sheet on top
  - E. **Pressure Round:**
    1. 4 - blank answer sheet packets (with cover sheet/instructions)
    2. 4 - Pressure Round test sets
    3. Pressure Round Answer Key (in the Proctor Packet)
  - F. **College Bowl:**
    1. 4 - College Bowl score sheets
    2. College Bowl questions - 6 rounds (in the Proctor Packet)
  - G. Scratch paper (to be handed out as needed, but try not to waste it)
  - H. Electronic College Bowl Apparatus (CBA; usually distributed at dinner break)

ALL **COLORED** ANSWER SHEETS WILL BE COLLECTED BY YOU AND WILL BE TAKEN TO THE SCORING ROOM (by RUNNERS) AS SOON AS THEY ARE FILLED OUT BY COMPETITORS (AND PERHAPS GRADED BY YOU). COMPETITORS CAN KEEP ALL OF THE WHITE SHEETS, IF THEY WOULD LIKE (OTHERWISE COLLECT THEM FOR RECYCLE).

If you are missing anything, you can go get it before the opening ceremony. After the opening ceremony, contact the proctor supervisor/scoring room.

2. Take a photo of how the classroom is laid out (so that it can be returned to its original configuration following the competition). Then set up the classroom desks for the first event (Mental Math).

**Respect the teacher whose room you are using. Do not touch their computer or other items. Do not erase anything on their board. Leave the room tidy & in the exact original layout.**

### **Mental Math**

3. Arrange desks in a configuration suitable for individual testing (rows/grid of desks all facing forward, students in separated/alternating desks).

4. Put the Mental Math answer sheets face up on the desks such that students are spread out. Wait for students to arrive. ~~You can fill out the proctor name and room number (and perhaps team numbers) on all blank answer sheets, if you like.~~ Read over the questions so you will be prepared to read them out loud.
5. After students sit down, check to make sure that no one from the same team is seated next to each other (i.e., "Team xxx, raise your hands."). Ask them to move, if needed.
6. **Check to make sure that students put their full name, school name, team number, and room number on their answer sheet and that the information is legible.**
7. Read the "GENERAL INSTRUCTIONS" (in the Proctor Packet) to the students. Then, read the "MENTAL MATH" instructions (in the Proctor Packet) to the students.
8. Begin the testing. Read each of the eight Mental Math questions to all of the students in the room, per the instructions.
9. At the conclusion of Mental Math, collect the answer sheets. Organize the answer sheets by team number, then alphabetically by first name of competitor. Staple each team's set of four answer sheets together. Promptly hand the packets of answer sheets to your runner for conveyance to the scoring room.

### **Individual Test**

10. The seating configuration will remain unchanged (no swapping seats).
11. Hand out Individual Test packets with the colored blank answer sheet facing up. **Check to make sure that students put their full name, school name, team number, and room number on their answer sheet and that the information is legible.**
12. Read the "INDIVIDUAL TEST" instructions (in the Proctor Packet) to the students and begin the testing at the appointed time.
13. While students are taking the Individual Test, monitor the students for proper test-taking behavior and watch the time to provide 5-minute and 30-second warnings. Make sure students are writing answers on the answer sheet (not the test question pages). During this time you can also get the Individual Multiple Choice tests ready, read through the rules of subsequent events, and (carefully/secretively) look ahead to review the College Bowl questions (i.e., to avoid stumbling over the wording when it comes time to read the questions aloud). You will have observers in the room watching the College Bowl rounds, so make sure you understand the rules, how timing works, etc.
14. At the conclusion of Individual Test, collect the answer sheets. Organize the answer sheets by team number, then alphabetically by first name of competitor. Staple each team's set of four answer sheets together. Promptly hand the packets of answer sheets to your runner for conveyance to the scoring room. Students may keep or recycle their test question packets.

## Individual Multiple Choice

15. Keep the room in the same configuration as for the Individual Test.
16. Hand out the tests and have students fill out the top portion of the answer sheet.  
**Check answer sheets to make sure they are filled out correctly (school, team #, etc.).**
17. Read the "INDIVIDUAL MULTIPLE CHOICE" instructions (in the Proctor Packet) to the students and begin the testing at the appointed time.
18. Monitor the students for proper test-taking behavior (no talking permitted), watch the time, and provide 5-minute and 30-second warnings. While students are taking the Individual Multiple Choice test, get the Team Tests ready.
19. At the conclusion of the test, collect the answer sheets. Organize the answer sheets by team number, then alphabetically by first name of competitor, with the set of team answer sheets stapled together. Hand the answer sheets off to the runner.

## Team Test

20. Change the room set-up to groups of 4 desks together so students can work as a team. Hand out the Team Test packets and have teams fill out the information at the top of the colored answer sheet. **Check the answer sheets to make sure they are filled out correctly (school, team #, etc.).**
21. Read the "TEAM TEST" instructions (in the Proctor Packet) to the students and begin the testing at the appointed time.
22. Monitor the students for proper test-taking behavior (talking is allowed), watch the time, and provide 5-minute and 30-second warnings. While students are taking the Team Test, get the Pressure Round tests ready.
23. At the conclusion of the test, collect the answer sheets & hand them off to the runner.

## Pressure Round

24. Leave the desks in the same arrangement as the team test. Make sure that all teams can quickly and easily hand you their answer sheet every two minutes.
25. Hand out the colored half-sheet packets to each team so they can fill out their school name and team number on each sheet before testing begins.
26. Have each team tear off the first sheet and give it to you to keep score.



27. YOU WILL BE TIMING THIS EVENT FOR YOURSELF. GIVE THEM A VERBAL 5 SECOND WARNING AND TELL THEM TO HOLD THEIR ANSWER SHEETS UP IN THE AIR EVERY TWO MINUTES. Tell them when the time is up for each two-minute round and, if an answer sheet isn't up in the air all the way at this time, then collect, but score as a zero and just write "time" on the score sheet for that particular question.
28. While they are working on the next round, you need to grade the answer sheets that you just collected and score it on the score sheet. Stack each team's half-sheets in **the order that they were turned in**, keeping the score sheet on top. Remember, you are still timing while you are doing all this!
29. Read the "PRESSURE ROUND" instructions (in the Proctor Packet) to the students and begin the testing at the appointed time.
30. At the conclusion of the fifth round, staple each team's half-sheets together, with the score sheet on top. Wait for the runner to come pick up the four packets before leaving for break.

### **Dinner Break**

31. AT BREAK — Eat dinner in the proctor room. Pick up your College Bowl apparatus (CBA) at this time. If you haven't already, you may want to read over the College Bowl questions to make sure you will be able to pronounce everything properly. Return to your room in time to place the CBA in position.

### **College Bowl Rounds**

32. Place the CBA on the middle desk of the line at the front of the room (you may want to moisten the suction cups with a film of water). One proctor may need to hold the device down (and do timing). Do not press the button to "reset" the CBA (it's an on/off switch).
33. You will have the same teams that were previously in the room for the duration of all College Bowl rounds — if you have an extra/different team, they are in the wrong room and can be disqualified if they hear the questions! Help get them to the correct room.
34. Fill out the score sheets for each team in your room with their school name and team number. Call up the first 2 teams according to the sequence on the room envelope.
35. You will be reading Round #1 questions to two teams while the other two teams (and any spectators) wait in the back of the room out of line of sight of the competitors. Refer to the College Bowl schedule (on your room envelope) to see which two teams compete in each round. If a round only has one team, they will be competing against the clock and thus will have 30 seconds to answer, not 45 seconds. Record the final scores for each team on their score sheets (which you hold on to) after each round. Rounds 2-6 work the same way. Refer to the schedule to make sure the correct

teams are competing at the correct time. Don't get ahead of schedule (or behind, for that matter!). If you finish a round early, please wait until the appointed time to start the next round. If you have any problems (including anyone questioning the rules or a decision made by a proctor) contact the proctor supervisor.

36. Who is keeping score? Who is keeping track of the time? YOU ARE !!!
37. Read the "COLLEGE BOWL" instructions (in the Proctor Packet) to all the students (just one time), then begin the testing for each round at the appointed times.
38. If you mis-read a question, replace it with one of the extra questions.
39. If a parent/coach/student protests an answer, make a note of the situation (the test, the problem number, who answered, what their answer was, etc.) and kindly state that the coach should bring up the issue with the contest director. Proceed as normal, scoring the question based on the answer key.
40. At the conclusion of all College Bowl rounds, get the score sheets promptly to the scoring room (either yourself or via a runner).
41. Release your group to the awards ceremony no earlier than 7:45 PM to avoid causing a disruption to other rooms. Have students help re-set the room.
42. At the end of the day, return the desks to their original arrangement, collect all scratch paper, erase any marks you made on the whiteboard, and generally make sure the classroom is tidied up. Return the College Bowl apparatus, proctoring envelope, and residual material to the proctor supervisor.

# General Instructions

- Good sportsmanship is expected throughout the competition by all involved (competitors and observers). Display of poor sportsmanship will result in disqualification.
- Competitors may not use calculators or any other aids on any portion of this contest.
- Unless stated otherwise:
  - All answers will be an integer, with the exception of the Multiple Choice test.
  - ~~Express all rational, non-integer answers as common fractions, except in problems dealing with money, where you should give the answer as a decimal rounded to the nearest cent.~~
  - ~~For fifth grade and up, all fractions and ratios must be reduced to simplest form, all radicals must be simplified, and all denominators must be rationalized.~~
  - ~~Do not round or approximate answers. Leave answers in terms of  $\pi$  or other irrational quantities (e.g.,  $\sqrt{2}$ ), where applicable.~~
- Units are not necessary as part of your answer, ~~unless it is a problem that deals with time, in which case, AM or PM is required.~~ However, if you choose to use units, they must be correct.
- Record all answers on the colored cover sheets in the answer column only.
- **Be sure that the student name, school, team number, etc. has been filled out at the top of each answer sheet.**
- Tests will be scored as a 0 if answers are not recorded correctly on the answer sheets.
- Blank answer sheets and answer sheets with no name will be scored as a 0.

# Mental Math Instructions

All students in the room will concurrently be asked the same eight questions in this individual test. When it is time to begin, the proctor will read the first question twice. You may not do any writing or talking while arriving at a solution. Once you have a solution, record it on the sheet in front of you. **You may not change or cross out answers once you have written an**

answer down. **If there are eraser marks, write-overs, or crossed-out answers, they will be marked wrong.** Once all students have laid their pencils on the desk, another question will be asked. If a student doesn't lay his or her pencil down, the maximum wait time is 30 seconds after completion of the second reading of the question before the next question is read. You may continue to work on a problem (in your head) while the next question is being read. The raw score is 1 point per correct answer.

## Individual Test Instructions

You will have 35 minutes to work on the Individual test, which consists of 40 questions. When you are prompted to begin, tear off the colored sheet and begin testing. Make sure your name and school are recorded on the answer sheet. The first 30 questions are worth two points each and questions 31-40 are worth 3 points each. Record your answers on the score sheet. No talking during the test. You will be given a 5 minute warning.

## Individual Multiple Choice Instructions

You will have 15 minutes to answer 10 multiple choice questions. This test is taken individually, but it is part of your team score, which will be calculated by taking the mean of the top 3 scores from your team. This test is the only test where you will be penalized for incorrect responses. You will receive two points for a correct letter response, zero points for leaving it blank, and minus one point for an incorrect response. When you are prompted to begin, tear off the colored answer sheet and begin testing. **ONLY a letter response should be listed as an answer on this answer sheet.**

## Team Test Instructions

You will have 15 minutes to answer 10 questions as a team. When you are prompted to begin, tear off the colored answer sheet and give a copy of the test to each of your team members and begin testing. Each problem is scored as a 1 or 0. Record all answers on this colored answer sheet.

# Pressure Round Instructions

When it is time to begin, you will be handed a packet of five problems. There is a copy of the problems for each team member. Two minutes after the start of the test you are expected to submit an answer for one of the problems. The problems need not be submitted in order; you can submit an answer for any of the problems, and your answer can be a guess, if you like. The maximum value of this first submitted answer is 1 point.

In another two minutes, you are expected to submit another answer to any one of the four remaining problems (you cannot submit a new answer for a previously submitted problem). The maximum value is two points for this second submittal.

This process will continue until all of the problems are answered. Each consecutive submitted answer increases in score value by one point.

You must submit your answers on the colored sheets given to you. If you do not have an answer at the end of a two-minute period, you must still submit an answer sheet with an identified problem number on it. Failure to do so will result in loss of points.

This event is timed, and you will be given a verbal 5 second warning prior to the end of each two-minute period. You will be told to hold your answer sheet up in the air for the proctor to collect. You may keep working as the answer sheets are collected. If a team answers the same question more than once, only the first answer will be scored and the other attempts will be ignored.

# College Bowl Instructions

## **Read these to the competitors before the first round:**

To maintain the integrity of the competition, spectators must stay in this room during a round of College Bowl questions. Once all readings for a round have been completed, you may leave.

All competitors must be facing the front of the room in one row. Teams not competing in the current round need to be behind the front row and in front of the spectators. All spectators need to be behind the competitors at the back of the room.

A maximum of ten questions per round will be scored. It is OK for both teams to score the same number of points! The proctor will record the points earned on each team's score sheet, which is retained by the proctor.

You may use scratch paper and pencil. You may talk with your team members while arriving at a solution.

An Electronic College Bowl Apparatus (CBA) will be used to identify the team who is first to have an answer.

During these rounds, each question will be read twice and a maximum time of 45 seconds after the second reading of the question is completed will be allowed for a team to answer. If a team buzzes in after the second reading and gives an incorrect response, the other team has the remainder of the 45 seconds to respond. A team is allowed only one attempt at buzzing in and answering per question. You may interrupt (buzz in) while a question is being read, however, if you do, the proctor will stop reading, and an immediate response is needed. If the correct response is given, the proctor will proceed to the next question. Otherwise, the question will be re-read for the other team, making sure it has two full readings. If an immediate response is not given after a team buzzes in, their lack of an answer in a timely manner is considered incorrect. In the event that only one team is competing in a round (i.e., one team is absent), the team competing will have a maximum of 30 seconds after the completion of the second reading in which to buzz in. The proctor will give a 5-second time warning.

Wait to be acknowledged by the proctor before giving an answer. This avoids the situation of blurting out an answer when the other team buzzed in first.

If two students from the same team answer at the same time with different answers, the answer will be considered incorrect.

If a problem arises with one of the questions, an extra question will be asked to replace that question.

If the round finishes early, you need to stay in the room for the remaining time.

# **Mental Math Questions**

## **Pressure Round Answers**

## **College Bowl Questions/Answers**