

# "Math Is Cool" Masters — 2023-24

7<sup>th</sup>/8<sup>th</sup> Grade — April 27, 2024

Sponsored by:

## **GENERAL INSTRUCTIONS applying to all tests:**

- *Good sportsmanship is expected throughout the competition by all involved (competitors and observers). Display of poor sportsmanship will result in disqualification.*
- *Competitors may not use calculators or any other aids on any portion of this contest.*
- *Unless stated otherwise:*
  - *All answers are integers and must be answered as integers. Any non-integer answers will be "coded" as integers.*
  - *All fractions and ratios must be reduced to simplest form, all radicals must be simplified, and all denominators must be rationalized.*
  - *Do not round or approximate answers. Leave answers in terms of  $\pi$  or other irrational quantities (e.g.,  $\sqrt{2}$ ), where applicable.*
- *Units are not necessary as part of your answer, However, if you choose to use units, they must be correct.*
- *Record all answers on the colored cover sheets in the answer column only.*
- ***Be sure that the student name, school, team number, etc. has been filled out at the top of each answer sheet.***
- *Tests will be scored as a 0 if answers are not recorded correctly on the answer sheets.*
- *Blank answer sheets and answer sheets with no name will be scored as a 0.*

## **FINAL SCORES AND AWARDS**

*Individual awards are determined by both the Mental Math and Individual Test scores. Individual ties are broken based on the following, in this order: total scaled individual points, total number of correct answers on the Individual Test, Mental Math raw score, number of correct answers from Individual Test #31-40, number of correct answers from Individual Test #16-30, highest numbered question answered correctly on the Individual Test working backwards from #40.*

*Team (School) awards are based on the highest score from amongst each of the school's "teams of 4 students" in each event and is calculated as  $2 \cdot (\text{Sum of highest 3 Mental Math scores}) + 2 \cdot (\text{Multiple Choice}) + 6 \cdot (\text{Team}) + 1 \cdot (\text{Triple Jump}) + 1 \cdot (\text{College Bowl})$ , for approximate weights of 25%, 20%, 30%, 15% and 10% respectively. Team ties are broken based on highest event score in order of the events, starting with Mental Math.*

## **MENTAL MATH TEST** - 30 sec./quest., 8 problems, ~8%/25% of individ./team scores

*The proctor will read each question twice. You may not do any writing or talking while arriving at a solution. Record only your answer on your answer sheet. You may not change, cross out, erase, or write over an answer once you have written it down. The maximum wait time is 30 seconds after completion of the second reading of the question. Correct answers receive 1 point.*

## **INDIVIDUAL TEST** - 35 minutes, 40 problems, ~92% of individual score

*When you are prompted to begin, tear off the colored answer sheet and begin testing. No talking during this individual test. You will be given a 5 minute time warning. Correct answers receive 2 points for problems 1-30 and 3 points for 31-40 (in the scaled score).*

# "Math Is Cool" Masters – 2023-24

7th/8<sup>th</sup> Grade – April 27, 2024

Final Score (out of 8)
------------------------

Room # \_\_\_\_\_ School Name \_\_\_\_\_ Student Name \_\_\_\_\_ Team # \_\_\_\_\_

## Mental Math - ~25% of team score & ~8% of individual score

All students in the room will concurrently be asked the same eight questions in this individual test. When it is time to begin, the proctor will read the first question twice. You may not do any writing or talking while arriving at a solution. Once you have a solution, record it on the sheet in front of you. You may not change or cross out answers once you have written an answer down. If there are eraser marks, write-overs, or crossed-out answers, they will be marked wrong. Once all students have laid their pencils on the desk, another question will be asked. If a student doesn't lay his or her pencil down, the maximum wait time is 30 seconds after completion of the second reading of the question before the next question is read. You may continue to work on a problem (in your head) while the next question is being read. The raw score is 1 point per correct answer.

STUDENT: DO NOT WRITE IN SHADED REGIONS (or anywhere else, other than the answer box)

Answer		Scorer 2	Scorer 1
		0 or 1	0 or 1
1			
2			
3			
4			
5			
6			
7			
8			
7th/8 <sup>th</sup> Grade		TOTAL:	

# "Math Is Cool" Masters — 2023-24

7th/8<sup>th</sup> Grade — April 27, 2024

Key

## Mental Math Contest - Answer Key

30 seconds per question - ~25% of team score & ~8% of individual score

**SCORERS** — Write-overs, Cross-outs, and Erasures Must be Marked Incorrect (0)  
Bracketed items [...] in the answer key are optional.

## 7th/8<sup>th</sup> Grade

Answer		
1	70	What is the sum of the largest prime number less than thirty and the smallest prime number greater than forty?
2	39 [integers]	How many integers are there from twenty-seven to sixty-five inclusive?
3	60[=5x]	If three X equals thirty-six, then what does five X equal?
4	51 [=A + B]	The probability of drawing a red ten from a standard deck of cards is one over twenty-six. As a reduced common fraction, the probability of not drawing a red ten is A over B. What is A plus B?
5	72 [pints]	An amphora was a unit of measurement of volume in Greco-Roman times and is equal to nine U.S. customary gallons. How many pints are in an amphora?
6	64 [jelly beans]	A bowl has thirty red jelly beans, twenty green jelly beans, fifteen blue jelly beans, six white jelly beans, and eleven black jelly beans. If jelly beans are taken from the bowl at random, how many must be taken to guarantee two green jelly beans have been taken?
7	144 [seconds]	Jacob takes three minutes to run a lap on a certain track. Jackson runs at an average rate that is one-and-a-quarter times as fast as Jacob. In seconds, how long does it take Jackson to run a lap on the same track?
8	23 [= P + Q]	If A is seventy percent of B, and B is five-eighths of C, then as a reduced common fraction A over C equals P over Q. What is P plus Q?

# "Math Is Cool" Masters — 2023-24

7th/8<sup>th</sup> Grade — April 27, 2024

## Individual Contest

Record all answers on the colored cover sheet. 35 minutes, 40 problems, ~92% of individual score.

No talking during this individual test. A 5-minute time warning will be given.

Questions 1-30: 2 points each	
1	The probability of rain on a certain Monday is 35%. As a percent, what is the probability that it won't rain on that same Monday?
2	In a standard 52-card deck of playing cards, how many cards are black multiples of 2?
3	In how many orders can three friends stand in line at a concession stand?
4	The ratio of cats to dogs in a shelter is 4:3. How many cats are there if there are 27 dogs in the shelter?
5	What is the largest 2-digit multiple of 17?
6	Kyla has \$3.55 worth of nickels. How many nickels does she have?
7	Evaluate $3x - 15y$ if $x = 45$ and $y = 9$ .
8	How many centimeters are in one-half of a meter?
9	Cici reads a 1000-word article in five minutes. How many words per minute is Cici's reading rate?
10	Tim is 5 feet 11 inches tall, Tara is 5 feet 5 inches tall, and Tanya is 5 feet 2 inches tall. In inches, what is the mean of the three heights?
11	Evaluate: $3 \cdot 5^2 - 104/4$
12	What percent of 175 is 35?
13	The first three terms of an arithmetic sequence are 6, 13, 20. What is the ninth term in the sequence?
14	My pin consists of three digits $a$ , $b$ , and $c$ , where $a < b < c$ . If $b - a = c - b$ , and $c = 9$ , then what is the largest possible value of $a + b$ ?
15	A 12 cm by 20 cm rectangle is divided into 16 smaller congruent rectangles. What is the perimeter in cm of one of the smaller rectangles.
16	An American football field is 120 yards by $53\frac{1}{3}$ yards. In square feet, what is the area of an American football field?
17	Four rogues can disarm 12 traps in 44 minutes. In minutes, how long will it take 2 rogues to disarm 9 traps?
<b>Continued on next page.</b>	

18	Evaluate: $1 + \frac{1}{3} + \frac{1}{\frac{1}{3}} + \frac{1}{\frac{1}{\frac{1}{3}}} + \frac{1}{\frac{1}{\frac{1}{\frac{1}{3}}}} + \frac{1}{\frac{1}{\frac{1}{\frac{1}{\frac{1}{3}}}}}$
19	A rectangular prism has dimensions 3 cm by 5 cm by 8 cm. A second rectangular prism has dimensions 9 cm by 25 cm by 64 cm. As a reduced common fraction, the ratio of the volume of the first prism to the volume of the second prism is A/B. What is A + B?
20	<p>In the Venn Diagram shown here, the Universal set is all integers from 1 to 30, inclusive. Let A = the number of integers inside the rectangle, but outside the two overlapping ovals. Let B = the number of integers inside the Perfect Squares oval not including the part where it overlaps with the Composite Numbers oval. Let C = the number of integers in the overlap of the two ovals. Let D = the number of integers in the Composite Numbers oval not including the overlap with the Perfect Squares oval. What is D - A?</p> <div data-bbox="748 495 1487 894" style="border: 1px solid black; padding: 10px; margin: 10px auto; width: fit-content;"> <p style="text-align: center;">U= Integers from 1 to 30</p> </div>
21	What is the sum of all possible solutions for x in the following equation? $\sqrt{28 - 2x} = x - 2$
22	A standard 8-sided die (numbered 1 - 8) is rolled with a standard 20-sided die (numbered 1 - 20). As a percentage, what is the probability that doubles are rolled?
23	On a coordinate plane, point A is 1 unit to the right of the origin. Point B is 4 units directly above point A, point C is 9 units directly to the left of point B and point D is 16 units directly below point C. In simplest radical form, point D is $X\sqrt{Y}$ units from the origin. What is X + Y?
24	Four positive integers are represented by A, B, C, and D. The positive difference between A and D is 10. The positive difference between B and C is 9. The positive difference between the two smallest integers is 1. The largest of the four integers is represented by D, and the smallest of the four integers is represented by B. What is the value of C - A?
25	The solution to the following inequality is $x > N$ , where N is a reduced common fraction in the form A/B. What is A + B? $\frac{5}{3}x - \frac{7}{9} > \frac{1}{6}x + \frac{11}{12}$
26	What is the largest 2-digit integer that is the product of three distinct prime numbers?
27	A data set of nine positive integers has a distinct mode equal to 12. The mean and median of the set are also 12. What is the largest possible number in the set?
28	How many 3-digit integers exist such that the product of the three digits is 24?

Continued on next page.

29	Let A equal 300% of B, 600% of C, and 800% of D. As a reduced common fraction $(B + C + D)/A = P/Q$ . What is $P + Q$ ?
30	Let $6250/3072$ be the first term of a geometric sequence with a common ratio of $4/5$ . Let the $N^{\text{th}}$ term of the sequence be the first term with a value less than $1/2$ . What is $N$ ?

**Challenge Questions: 3 points each**

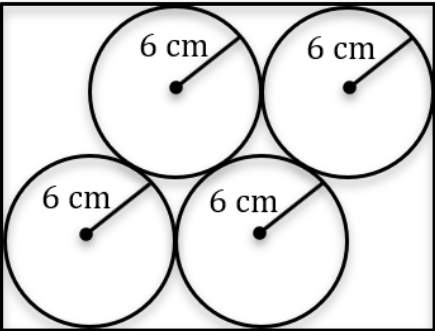
31	As a reduced common fraction, the median of the following data set is $A/B$ . What is $A + B$ ? $\frac{9}{14'}$ $\frac{24}{29'}$ $\frac{21}{26'}$ $\frac{15}{20'}$ $\frac{18}{23'}$ $\frac{12}{17}$
32	What is the product of $102_3 \cdot 132_5$ in base-4?
33	A sequence of integers is generated according to the following rules. If any term is a perfect square, the next term is its square root. If a term is an even number and not a perfect square, it has an odd number added to it. The first non-perfect square even number in the sequence has 1 added to it, the second non-perfect square even number has 3 added to it, and so on, adding a successive odd number to each successive non-perfect square even number. Successive non-perfect square odd numbers in the sequence are multiplied by successive even numbers, beginning with the first non-perfect square odd number being multiplied by 2, the next non-perfect square odd number being multiplied by 4, and so on. What is the 14th term in the sequence if the first term is 10?
34	An unfair penny has a probability of flipping heads of $2/5$ , an unfair nickel has a probability of flipping heads of $3/7$ , and an unfair dime has a probability of flipping heads of $6/11$ . When the three coins are flipped together, as a reduced common fraction the probability of at least two of the coins showing heads is $A/B$ . What is $A + B$ ?
35	Biff and Eho are running at steady rates in opposite directions on a circular track. Biff takes 120 seconds to complete a lap while it takes Eho 180 seconds to complete a lap. Once they pass each other, how many seconds will it take them to pass each other again?
36	The vertices of a regular octahedron are labeled with the integers 1 through 6, in some order, with each integer used exactly once. Each edge of the octahedron is labeled with the sum of the integers at its endpoints. Each face is labeled with the product of the labels of its three edges. What is the largest possible difference between the labels of any two adjacent faces?
37	In the figure shown, there are four congruent circles that are externally tangent to each other and that are internally tangent to the sides of the surrounding rectangle. The radius of each circle is 6 cm. In centimeters, the perimeter of the rectangle is $A + B\sqrt{C}$ . What is $A + B + C$ ? Note: the value of $C$ does not have a factor that is a perfect square other than 1.
	
38	A box contains only dimes and nickels. If there were 20% more dimes, there would be 6% more money in the box. As a reduced common fraction, the ratio of the original number of dimes to the original number of nickels in the box is $A/B$ . What is $A + B$ ?

Continued on next page.

39	Consider the equation $\sqrt{56 + 6\sqrt{55}} = \sqrt{A} + B\sqrt{C}$ , where A, B, and C are positive integers and neither A nor C has a factor that is a perfect square other than 1. What is $A + B + C$ ?
40	In a hand of 7 cards drawn from multiple standard decks there are two identical Ace of Spades, two identical Jack of Hearts, and three cards that are distinct from the Aces and Jacks and from each other. In how many distinct ways can the cards be put in order if the Aces cannot be next to each other and the Jacks cannot be next to each other?

**IF taking Algebra or Geometry, continue to questions 41 - 42.**

41	The formula for converting degrees Celsius to degrees Fahrenheit is $F = \frac{9}{5}C + 32$ , where F = degrees Fahrenheit and C = degrees Celsius. To obtain the formula for converting degrees Fahrenheit to degrees Celsius, solve the equation for C. The result is $C = \frac{R}{P}(F - Q)$ , where $\frac{R}{P}$ is a reduced common fraction and R, P, and Q are positive integers. What is $R + P + Q$ ?
42	How many solutions (x, y) to the following equation exist such that both x and y are positive integers? $6x + 11y = 165$

**IF taking Geometry, continue to questions 43 - 45.**

43	The following expression can be simplified to the binomial $Ax + B$ , where A and B are positive integers. What is $A + B$ ?
----	--

$$\frac{10x^3 + 9x^2 - 109x + 60}{10x^2 - 31x + 15} = Ax + B$$

44	The volume of a rectangular pyramid is $374 \text{ cm}^3$ . If the length and width of the base are 6 cm and 11 cm, what is the number of centimeters in the height of the pyramid?
----	---

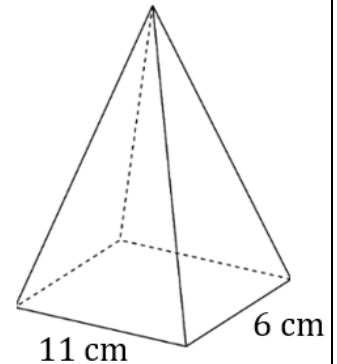

45	In the figure shown the area of $\triangle ABC$ is $72 \text{ cm}^2$ , $AB = 9 \text{ cm}$ , and $DE = 6 \text{ cm}$ . In centimeters and as a reduced common fraction $AD = P/Q$ . What is $P + Q$ ?
----	---

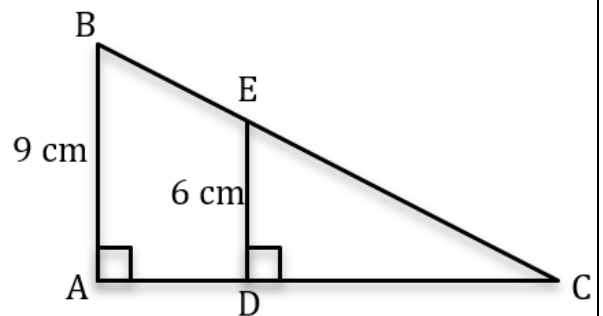

# "Math Is Cool" Masters - 2023-24

**KEY**

## 7<sup>th</sup>/8<sup>th</sup> Grade Individual Contest - Answer Key

SCORERS: Bracketed [...] items in answer key are optional. Just mark the score as 0 or 1 and add up those values to reflect total correct.  
First Scorer - use the right-hand columns so 2<sup>nd</sup> scorer can do a blind scoring.

	Answer
1	65 [%]
2	10 [cards]
3	6 [orders]
4	36 [cats]
5	85
6	71 [nickels]
7	0
8	50 [cm]
9	200 [words per minute]
10	66 [inches]
11	49
12	20 [%]
13	62
14	[ $a + b =$ ] 15
15	16 [cm]

	Answer
16	57600 [ $ft^2$ ]
17	66 [minutes]
18	8
19	[ $A + B =$ ] 121
20	[ $D - A =$ ] 5
21	[ $x =$ ] 6
22	5 [%]
23	[ $X + Y =$ ] 17
24	[ $C - A =$ ] 8
25	[ $A + B =$ ] 115
26	78
27	55
28	21 [integers]
29	[ $P + Q =$ ] 13
30	[ $N =$ ] 8

	Answer
31	[ $A + B =$ ] 325
32	13032 <sub>[4]</sub> [base 4]
33	3061
34	[ $A + B =$ ] 79
35	72 [seconds]
36	720
37	[ $A + B + C =$ ] 99
38	[ $A + B =$ ] 17
39	[ $A + B + C =$ ] 19
40	660
41	[ $R + P + Q =$ ] 46
42	2 [solutions]
43	[ $A + B =$ ] 5
44	17 [cm]
45	[ $P + Q =$ ] 19



# "Math Is Cool" Masters - 2023-24

Total Correct (all columns)
-----------------------------

Room # \_\_\_\_\_ SCHOOL NAME \_\_\_\_\_ STUDENT NAME \_\_\_\_\_ Team # \_\_\_\_\_

## 7<sup>th</sup>/8<sup>th</sup> Individual Contest - Score Sheet

STUDENTS: DO NOT WRITE IN SHADED REGIONS

	Answer	1 or 0	1 or 0
1			
2			
3			
4			
5			
6			
7			
8			
9			
10			
11			
12			
13			
14			
15			
<b>1-15 TOTAL:</b>			

	Answer	1 or 0	1 or 0
16			
17			
18			
19			
20			
21			
22			
23			
24			
25			
26			
27			
28			
29			
30			
<b>16-30 TOTAL:</b>			

	Answer	1 or 0	1 or 0
31			
32			
33			
34			
35			
36			
37			
38			
39			
40			
41			
42			
43			
44			
45			
<b>31-45 TOTAL:</b>			

# "Math Is Cool" Masters — 2023-24

7th/8<sup>th</sup> Grade — April 27, 2024

## Team Multiple Choice Contest

REFER TO THE FOLLOWING INFORMATION FOR PROBLEMS #1 THROUGH #3.

A semiprime is a natural number that is the product of exactly two prime numbers (not necessarily distinct). For example, 22 is a semiprime, because  $22 = 2 \cdot 11$  and both 2 and 11 are prime numbers, whereas 12 is not a semiprime, because it has at least one factor that is a composite number.

1	What is the largest 2-digit semiprime? A) 91      B) 93      C) 94      D) 95      E) 97
2	Some semiprimes are perfect squares. What is the sum of the smallest four 3-digit perfect-square semiprimes? A) 801      B) 876      C) 940      D) 1108      E) 1180
3	What is the positive difference between the largest 3-digit perfect-square semiprime and the smallest 2-digit non-perfect-square semiprime? A) 936      B) 937      C) 945      D) 947      E) 951

REFER TO THE FOLLOWING INFORMATION TO SOLVE PROBLEMS #4 THROUGH #7.

Consider the following data set: {10, 12, 14, 16, 18, 20}

4	What is the mean of the data set? A) 15      B) 18      C) 19      D) 20      E) 21
5	How many pairs of integers between 10 and 20 inclusive can be added to the data set, such that the mean does not change? Note: the order of the two integers does not matter and they may be the same as each other. A) 5      B) 6      C) 10      D) 11      E) 12
6	A random number in the set is replaced with a different integer between 10 and 20 inclusive. In other words, a number cannot be replaced by itself. What is the probability that the new median is greater than 15? A) 11/30      B) 2/5      C) 13/30      D) 7/15      E) 1/2
7	How many data sets consisting of 6 distinct two-digit positive integers have a mean of 14? A) 23      B) 26      C) 27      D) 28      E) 30

Continued on Next Page

REFER TO THE FOLLOWING INFORMATION FOR PROBLEMS #8 THROUGH #10.

Each lane in the track below consists of two straightaways and two semicircles. The length of the straightaways in both lanes is 30 meters. The width of each lane is 2 meters. The distance between the inner edge of the two straightaways on the inside lane is 60 meters. The inside lane is lane 1 and the outside lane is lane 2.

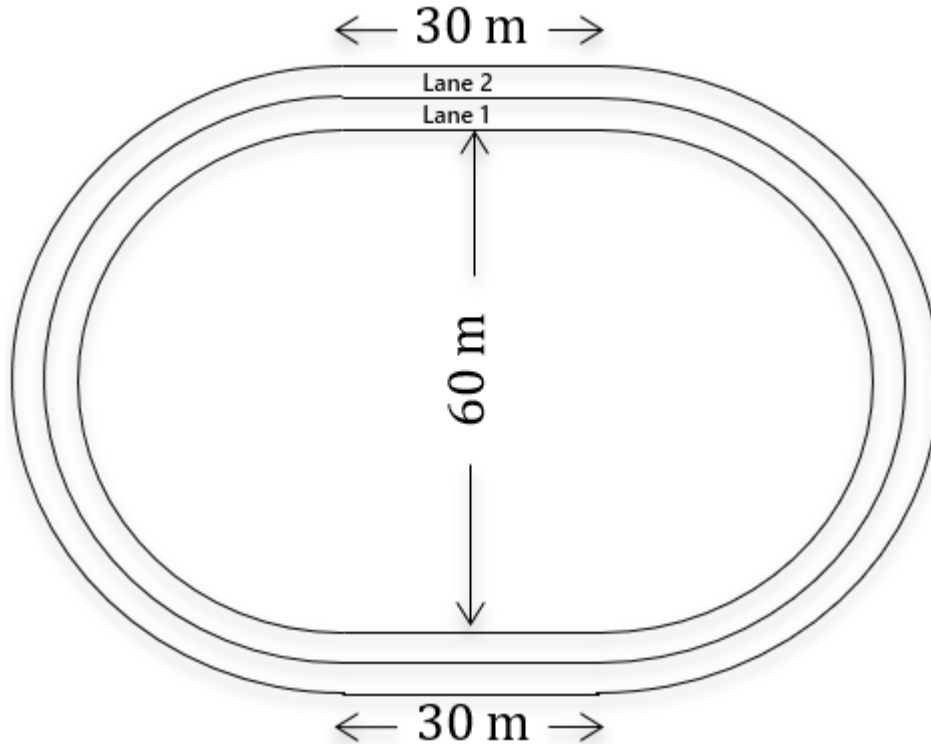

- 8 What is the shortest distance a runner can take in completing one lap in lane 2 of the track?  
Note: the shortest distance would be achieved by running directly on the inner edge of lane 2.
- A)  $60 + 32\pi$  meters    B)  $30 + 64\pi$  meters    C)  $60 + 64\pi$  meters    D)  $60 + 900\pi$  meters  
E)  $60 + 1024\pi$  meters
- 9 What is the area of lane 2?
- A)  $120 + 4\pi m^2$     B)  $120 + 64\pi m^2$     C)  $132\pi m^2$     D)  $60 + 132\pi m^2$     E)  $120 + 132\pi m^2$
- 10 One runner consistently runs the shortest distance within lane 1 and a second runner consistently runs the shortest distance within lane 2. Both runners start at the same time next to each other at one end of one of the straightaway sections and run at the same average rate and in the same direction. At some point the runner in lane 1 will pass the runner in lane 2. During which lap for the runner in lane 1 will this happen?
- A) 19<sup>th</sup> lap    B) 20<sup>th</sup> lap    C) 21<sup>st</sup> lap    D) 22<sup>nd</sup> lap    E) 25<sup>th</sup> lap

# "Math Is Cool" Masters — 2023-24

7th/8<sup>th</sup> Grade — April 27, 2024

**Key**

## Team Multiple Choice Contest - Answer Key

### 7th/8<sup>th</sup> Grade

Correct responses are worth 2 points, incorrect responses are worth -1 point, and absence of a response is worth 0 points.

	Answer
1	D
2	C
3	E
4	A
5	B
6	A
7	B
8	C
9	E
10	B

# "Math Is Cool" Masters — 2023-24

7th/8<sup>th</sup> Grade — April 27, 2024

Room # \_\_\_\_\_

School Name \_\_\_\_\_

Team # \_\_\_\_\_

## Team Multiple Choice Contest - 15 minutes - ~20% of team score

*This test is the only test where you will be penalized for incorrect responses. You will receive two points for a correct letter response, zero points for leaving it blank, and minus one point for an incorrect response. When you are prompted to begin, tear off the colored answer sheet, pass out a copy of the test to each team member, and begin testing. **ONLY a letter response should be listed as an answer on this answer sheet.***

**Correct responses are worth 2 points, incorrect responses are worth -1 point, and absence of a response is worth 0 points.**

**STUDENTS: DO NOT WRITE IN SHADED REGIONS**

Answer		Scorer 2	Scorer 1
		-1, 0, or 2	-1, 0, or 2
1			
2			
3			
4			
5			
6			
7			
8			
9			
10			
<b>7th/8<sup>th</sup> Grade</b>		<b>TOTAL:</b>	

# "Math Is Cool" Masters – 2023-24

7th/8<sup>th</sup> Grade – April 27, 2024

## Team Contest

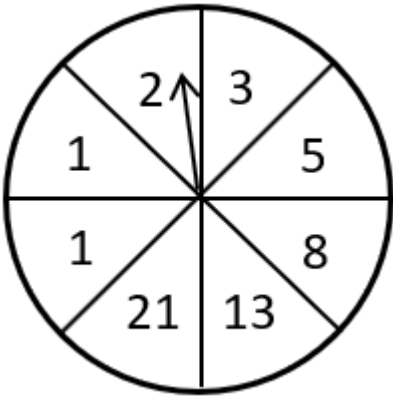
1	The area of a circle whose circumference is $36\pi$ centimeters is $A\pi$ cm <sup>2</sup> . What is $A$ ?
2	$A$ and $B$ are two different integers greater than 10, but less than 20. $C$ and $D$ are two different integers greater than 0, but less than 10. What is the greatest possible sum of $A + B + C + D$ ?
3	What is the median of the data set? {11, 200, 53, 162, 125, 71, 99}
4	Brianna takes 45 minutes to build 6 card houses. At this rate, how many card houses can Brianna build in 2 hours and 15 minutes?
5	The 8 sectors in the spinner shown below are congruent and the spinner is spun twice. The probability as a reduced common fraction that the sum of the two resulting numbers is 2 is $A/B$ . What is $A + B$ ?
	
6	Let $A = 30\%$ of $B$ and $50\%$ of $C$ . As a percent, what is $C/B$ ?
7	In how many different ways can you add together one or more perfect squares to make a sum of 30? The order of the numbers does not matter. For example, two different ways to get a sum of 40 would be (1) four 1s + nine 4s and (2) four 1s + one 36.
8	Marion has 180 ft of fencing material to use to enclose a rectangular part of her back yard. Her house is long enough to be used as one of the long sides of the enclosed rectangular area, so the fencing only needs to be used on the two short sides and the other long side of the rectangle. What is the number of square feet in the largest area that she can enclose with this amount of fencing?
<b>Continued on next page.</b>	

9 In the following grid, place each of the digits 1 through 9 into a box, using each digit exactly once, according to the following rules. What 3-digit integer is in Row 3, reading from left to right?

1. Every digit is smaller than the digit immediately to its right and smaller than the digit immediately below it.
2. The three digits in the second row sum to 15.
3. The three digits in the second column sum to 17.
4. The digit 5 is not in the first row.

	Col. 1	Col. 2	Col. 3
Row 1			
Row 2			
Row 3			

10 The integer 12 has exactly 6 factors, 1, 2, 3, 4, 6, and 12. All integers from 1 to 100, including 12 and having exactly 6 factors can be written in a list in ascending order. Let  $A$  and  $B$  be the two adjacent integers in the list that have the greatest difference between each other, where  $B > A$ . What is  $B - A$ ?

# "Math Is Cool" Masters — 2023-24

7th/8<sup>th</sup> Grade — April 27, 2024

Key

## Team Contest - Answer Key

### 7th/8<sup>th</sup> Grade

Answer	
1	[A =] 324
2	[A + B + C + D =] 54
3	99
4	18 [card houses]
5	[A + B =] 17
6	60 [%]
7	27 [ways]
8	4050 [ft <sup>2</sup> ]
9	589
10	[B - A =] 16



# "Math Is Cool" Masters — 2023-24

7th/8<sup>th</sup> Grade — April 27, 2024

Final Score (out of 10)

Room #

School Name

Team #

## Team Contest - 15 minutes - ~30% of team score

When you are prompted to begin, tear off the colored answer sheet and give a copy of the test to each of your team members and begin testing. Each problem is scored as a 1 or 0. Record all answers on this colored answer sheet.

STUDENTS: DO NOT WRITE IN SHADED REGIONS

Answer		Scorer 2	Scorer 1
		0 or 1	0 or 1
1			
2			
3			
4			
5			
6			
7			
8			
9			
10			
7th/8 <sup>th</sup> Grade		TOTAL:	

# "Math Is Cool" Masters — 2023-24

7th/8<sup>th</sup> Grade — April 27, 2024

## Linda Moore Triple Jump

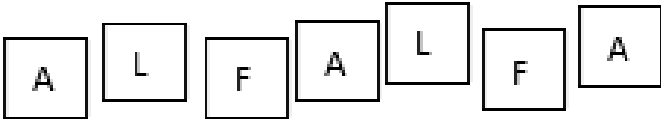
1	Evaluate: $(10 - 13) - 4 \cdot 5^2 + (84 \div 21)$
2	A cubit is an ancient unit of length, approximately equal to the length of a forearm. It was typically about 18 inches. Assuming a cubit equals 18 inches, how many cubits are in the length of a field that is 120 yards long?
3	Donald wants to give his penny collection to his three nephews, Huey, Dewey, and Louis. He gives Huey 25 percent of his pennies, he gives Dewey $\frac{2}{5}$ of his pennies, and he gives Louis the remaining 63 pennies. In total, how many pennies were in his collection?
4	The first three numbers in a sequence are 1, 4, and 8, where each successive term is generated by adding the number that corresponds to the number of characters used in the English spelling of the previous term. For example, 1 is spelled 'one', and $1 + 3 = 4$ . What is the 7th term in the sequence? Note: the spelling of a number like twenty-five includes a hyphen, which makes the character count in this case 11 characters.
5	The set of integers shown have the same median and mode. What is the value of N? {78, 15, 26, 60, 41, 37, 52, N}
6	The following expression can be simplified to a reduced common fraction $A/B$ . What is $A + B$ ? $\frac{\frac{3}{8} - \frac{5}{4} + \frac{7}{2}}{\frac{5}{8} - \frac{7}{4} + \frac{9}{2}}$
7	In the expression $AB - CD$ , $AB$ and $CD$ are 2-digit positive integers, and $A$ , $B$ , $C$ , and $D$ can each be replaced by a different one of the four digits, 2, 4, 7, and 9. What is the positive difference between the largest possible positive value and the smallest possible positive value of $AB - CD$ ?
8	Biff has a set of tiles spelling ALFALFA. Eho randomly chooses a set of 4 tiles from Biff's set without replacement. As a reduced common fraction, the probability that Eho can create a palindrome using all 4 tiles is $P/Q$ . What is $P + Q$ ? 

Continued on next page.

9 A square with perimeter twenty inches is inscribed inside a circle. As a simplified fraction the ratio of the area of the square to the circumference of the circle is  $\frac{A\sqrt{B}}{C\pi}$ , where A, B and C are single-digit integers. What is  $A + B + C$ ?

10 The positive integers are arranged in the following infinite pattern. Each integer has a certain row and column position, indicated by (r, c). For example, the number 9 is in position (2, 3). Find the location (r, c) that the number 2024 is in. What is the value of  $r - c$ ?

		Column Number:					
		1	2	3	4	5	6
Row Number:	1	1	3	6	10	15	...
	2	2	5	9	14	20	...
	3	4	8	13	19	26	...
	4	7	12	18	25	33	...
	5	11	17	24	32	41	...
	6	...	...	...	...	...	...

# "Math Is Cool" Masters — 2023-24

7th/8<sup>th</sup> Grade — April 27, 2024

Key

Linda Moore Triple Jump - Answer Key

## 7th/8<sup>th</sup> Grade

	Answer
1	-99
2	240 [cubits]
3	180 [pennies]
4	41
5	[N =] 41
6	[A + B =] 16
7	55
8	[P + Q =] 6
9	[A + B + C =] 9
10	[r - c =] 49

# "Math Is Cool" Masters — 2023-24

7th/8<sup>th</sup> Grade — April 27, 2024

Final Score (out of 10)

Room #

School Name

Team #

## Linda Moore Triple Jump - 15 minutes - ~30% of team score

When you are prompted to begin, tear off the colored answer sheet and give a copy of the test to each of your team members and begin testing. Each problem is scored as a 1 or 0. Record all answers on this colored answer sheet.

STUDENTS: DO NOT WRITE IN SHADED REGIONS

Answer		Scorer 2	Scorer 1
		0 or 1	0 or 1
1			
2			
3			
4			
5			
6			
7			
8			
9			
10			
7th/8 <sup>th</sup> Grade		TOTAL:	

# "Math Is Cool" Masters — 2023-24

7th/8<sup>th</sup> Grade — April 27, 2024

Room #

School Name

Team #

## Total Score for Each Round

College Bowl #1 (10 Possible)	College Bowl #2 (10 Possible)	College Bowl #3 (10 Possible)

DO NOT USE TALLY MARKS ON THIS SHEET. WRITE THE TOTAL SCORE FOR EACH ROUND.

# "Math Is Cool" Masters — 2023-24

7th/8<sup>th</sup> Grade — April 27, 2024

Room #

School Name

Team #

## Total Score for Each Round

College Bowl #1 (10 Possible)	College Bowl #2 (10 Possible)	College Bowl #3 (10 Possible)

DO NOT USE TALLY MARKS ON THIS SHEET. WRITE THE TOTAL SCORE FOR EACH ROUND.

# "Math Is Cool" Masters — 2023-24

7th/8<sup>th</sup> Grade — April 27, 2024

Proctor  
Copy

## Mental Math Contest

**MENTAL MATH** - 30 seconds per question - ~25% of team score & ~8% of individual score

All students in the room will concurrently be asked the same eight questions in this individual test. When it is time to begin, the proctor will read the first question twice. You may not do any writing or talking while arriving at a solution. Once you have a solution, record it on the sheet in front of you. **You may not change or cross out answers once you have written an answer down. If there are eraser marks, write-overs, or crossed-out answers, they will be marked wrong.** Once all students have laid their pencils on the desk, another question will be asked. If a student doesn't lay his or her pencil down, the maximum wait time is 30 seconds after completion of the second reading of the question before the next question is read. You may continue to work on a problem (in your head) while the next question is being read. The raw score is 1 point per correct answer.

1	What is the sum of the largest prime number less than thirty and the smallest prime number greater than forty?	70
2	How many integers are there from twenty-seven to sixty-five inclusive?	39 [integers]
3	If three X equals thirty-six, then what does five X equal?	60[=5x]
4	The probability of drawing a red ten from a standard deck of cards is one over twenty-six. As a reduced common fraction, the probability of not drawing a red ten is A over B. What is A plus B?	51 [=A + B]
5	An amphora was a unit of measurement of volume in Greco-Roman times and is equal to nine U.S. customary gallons. How many pints are in an amphora?	
6	A bowl has thirty red jelly beans, twenty green jelly beans, fifteen blue jelly beans, six white jelly beans, and eleven black jelly beans. If jelly beans are taken from the bowl at random, how many must be taken to guarantee two green jelly beans have been taken?	64 [jelly beans]
7	Jacob takes three minutes to run a lap on a certain track. Jackson runs at an average rate that is one-and-a-quarter times as fast as Jacob. In seconds, how long does it take Jackson to run a lap on the same track?	
8	If A is seventy percent of B, and B is five-eighths of C, then as a reduced common fraction A over C equals P over Q. What is P plus Q?	23 [= P + Q]

# "Math Is Cool" Masters — 2023-24

7th/8<sup>th</sup> Grade — April 27, 2024

**Key**

## COLLEGE BOWL ROUND #1

#	Problem	Answer
1	Solve for X: two hundred and forty minus fifteen X equals four hundred and fifty	$[x = ] -14$
2	What is fifty-one minus forty-two plus thirty-three minus twenty-four plus fifteen?	33
3	The first three terms of an arithmetic sequence are three, fourteen, and twenty-five. What is the eighth term in the sequence?	80
4	Axel's first three test scores are eighty-nine, seventy-six, and ninety-one. What average score does he need to get on the next two tests to bring his average to ninety?	97
5	If $\frac{X}{Y}$ equals $\frac{8}{9}$ and $\frac{Y}{Z}$ equals $\frac{3}{7}$ , then as a reduced common fraction $\frac{X}{Z}$ equals $\frac{A}{B}$ . What is A plus B?	$[A = B = ] 29$
6	A cylinder has a volume of one hundred and forty-four pi cubic inches. If the height of the cylinder is four inches, then the circumference of its base is A pi inches. What is A?	$[A = ] 12$
7	How many perfect cubes exist between three hundred and one thousand three hundred?	4 [perfect cubes]
8	How many square inches are in three-point-five square feet?	504 [ $\text{in}^2$ ]
9	In miles, how far does a car traveling at an average rate of forty-five miles per hour go in twenty-four minutes?	18 [miles]
10	Stef Curry has made ninety-one percent of his free throws in his career. Rounded to the nearest whole percentage and based on his career free throw percentage, what is the probability that he will make two free throws in a row?	83 [%]



# "Math Is Cool" Masters — 2023-24

7th/8<sup>th</sup> Grade — April 27, 2024

Key

## COLLEGE BOWL ROUND #2

#	Problem	Answer
1	A five-gallon bucket of paint costs forty-three dollars. In cents, what is the cost of the paint per quart?	215 [cents]
2	A short story is printed on thirty-three pages and every page is numbered, starting with page one. How many threes are printed in the page-numbering of the short story?	8 [threes]
3	The solution to the equation five X over nine equals twenty-five over six is X equals A point B, where A and B are single digits. What is A plus B?	[A + B =] 12
4	What is the sum of the positive factors of forty-eight?	124
5	Trapezoid ABCD has side AB parallel to side CD and side BC perpendicular to sides AB and CD. If AB equals seven inches, BC equals six inches, and CD equals fifteen inches, in inches what is the perimeter of ABCD?	38 [inches]
6	Six scrabble tiles have the letters A, B, C, D, E, and F on them. Three tiles are chosen at random without replacement. As a reduced common fraction, the probability that the first tile is A, the second tile is B, and the third tile is C is P over Q. What is P plus Q?	[P + Q =] 121
7	What is the sum of the first five terms in the geometric sequence whose first term is eight and whose common ratio is negative three?	488
8	A palindrome is an integer that reads the same forwards and backwards, such as one hundred fifty-one. What is the mean of the nine smallest palindromes that are greater than ten?	55
9	Let A, B, C, and D be distinct positive integers. If A equals seventeen and is greater than B and C and B is greater than C and D, then what is the largest possible value of D?	[D = ] 15
10	What is thirty-two times twenty-eight?	896

# "Math Is Cool" Masters – 2023-24

7th/8<sup>th</sup> Grade – April 27, 2024

**Key**

## COLLEGE BOWL ROUND #3

#	Problem	Answer
1	Evaluate: the quantity four divided by one-fourth minus the quantity three divided by one-third plus the quantity two divided by one-half.	11
2	What is the median of the prime numbers between forty-nine and sixty?	56
3	What is twelve percent of twenty-five?	3
4	Natalie takes five minutes to make three sandwiches. Penn takes six minutes to make four sandwiches. How many sandwiches can Natalie and Penn make working together in fifteen minutes?	19 [sandwiches]
5	What is the sum of the solutions to the equation: $X^2 - 6X - 72 = 0$ ?	6
6	Find the volume in cubic inches of a pyramid with a square base, where the side length of the base is thirteen inches and the height of the pyramid is nine inches.	507 [cubic inches]
7	The first five terms of a sequence are one, one, two, three, and five. As a reduced common fraction, the ratio of the tenth term over the ninth term is $\frac{A}{B}$ . What is $A + B$ ?	$[A + B =] 89$
8	What is the sum of the smallest two prime numbers that are greater than twenty and differ by four?	78
9	Aaron's number is ten more than Brian's number. Clarissa's number is six less than Brian's number. Deepta's number is two more than Clarissa's number, which is thirteen. What is the positive difference between Aaron's number and Deepta's number?	14
10	How many even numbers are between fifty-one and eighty-three?	16 [even numbers]

# "Math Is Cool" Masters — 2023-24

7th/8<sup>th</sup> Grade — April 27, 2024

Key

## COLLEGE BOWL ROUND #4

#	Problem	Answer
1	Four hundred times five hundred times six hundred times seven hundred equals $A$ point $B$ times ten to the $C$ in scientific notation, where $A$ and $B$ are positive single-digit integers, and $C$ is a positive integer. What is $C$ ?	$[C =] 10$
2	Solve the following equation for $X$ : Seven $X$ plus nineteen equals three $X$ plus thirty-one	$[x =] 3$
3	What is the sum of the first six terms in the series that begins with one and in which each successive term is two times the previous term?	63
4	Nine cards are numbered one through nine. Two cards are selected at random without replacement. As a reduced common fraction, the probability that the numbers on the cards add up to seven is $A$ over $B$ . What is $A$ plus $B$ ?	$[A + B =] 13$
5	A line with equation six $X$ plus nine $Y$ equals thirty-six is drawn on a coordinate plane. How many points, $X$ comma $Y$ , are there below the line in which both $X$ and $Y$ are positive integers?	7 [points]
6	My number is an integer between zero and fifty. It is not a multiple of two, three, or five. My number is between thirty-two and forty. What is my number?	37
7	One mile equals about one-point-six-one kilometers. Rounded to the nearest whole number, what is the number of square kilometers in three square miles?	8 [km <sup>2</sup> ]
8	Eighty is two hundred and fifty percent of $A$ . What is $A$ ?	$[A =] 32$
9	What is the median of the first six powers of five? In other words, five to the first through five to the sixth.	375
10	In minutes, how long does it take a train traveling at an average speed of twenty miles per hour to travel seven miles?	21 [minutes]

# "Math Is Cool" Masters — 2023-24

7th/8<sup>th</sup> Grade — April 27, 2024

Key

## COLLEGE BOWL ROUND #5

#	Problem	Answer
1	What is the sixth term in the arithmetic sequence whose first three terms are two hundred, one hundred sixty-one, and one hundred twenty-two?	5
2	A rectangle has a length of seven inches and width of twenty-eight inches. In inches, what is the perimeter of a square whose area is the same as the area of the rectangle?	56 [inches]
3	Evaluate: two to the fifth power plus three to the fourth power plus four to the third power	177
4	As a reduced common fraction, the median of the following data set is $A$ over $B$ . What is $A$ plus $B$ ? {eleven tenths, eleven halves, eleven eighths, eleven fourths}	$[A + B =] 49$
5	Jorge takes ten minutes to dig one hole. Laurie digs eight holes in one hour. The ratio of Jorge's hole-digging rate to Laurie's hole-digging rate in holes per second is $A$ over $B$ . What is $A$ plus $B$ ?	$[A + B =] 7$
6	When the two binomials five $X$ plus three and seven $X$ minus eight are multiplied the result is $A X$ squared plus $B X$ plus $C$ , where $B$ and $C$ are negative integers. What is $A$ plus $B$ plus $C$ ?	$[A + B + C =] -8$
7	A fun-size bag of M&Ms has three brown, four orange, two yellow, six green, and five blue M&Ms in it. If two M&Ms are randomly taken from the bag, the probability as a reduced common fraction that at least one of them is blue is $A$ over $B$ . What is $A$ plus $B$ ?	$[A + B =] 55$
8	Abe arrived first at the party. Bonita didn't arrive last. Carter arrived after Abe. Doris arrived after Bonita but before Carter. Who was the second person to arrive at the party. Answer as an integer: one for Abe, two for Bonita, three for Carter, or four for Doris.	2
9	Let two over three equal $X$ over thirty-six and let four over five equal $Y$ over eighty-five. If $X$ over $Y$ is a reduced common fraction, what is $X$ plus $Y$ ?	$[x + y =] 23$
10	One acre is equivalent to forty-three thousand five hundred and sixty square feet. How many square feet are in one ninetieth of an acre?	484 [ft <sup>2</sup> ]

# "Math Is Cool" Masters — 2023-24

7th/8<sup>th</sup> Grade — April 27, 2024

Key

## COLLEGE BOWL ROUND #6

#	Problem	Answer
1	What is the sum of all integers that are greater than the square root of twenty and less than the square root of sixty?	18
2	A bowl has red, green, and blue marbles in it, and one marble will be randomly selected. The probability of selecting a red marble is two over five and the probability of selecting a green marble is two over seven. As a reduced common fraction, the probability of selecting a blue marble is $A$ over $B$ . What is $A$ plus $B$ ?	$[A + B =] 46$
3	What is the mean of the odd numbers between six and sixteen?	11
4	Seven jiggles make four wiggles. Six wiggles make fifteen bobbles. How many jiggles do twenty bobbles make?	14 [jiggles]
5	How many distinct ways are there to arrange the letters in the word SENSES, spelled S-E-N-S-E-S, if none of the Ss can be next to each other?	12 [ways]
6	If four $X$ minus $A$ equals six $X$ minus $B$ and $B$ minus $A$ equals three, then $X$ equals $P$ point $Q$ , where $P$ and $Q$ are single-digit integers. What is $P$ plus $Q$ ?	$[P + Q =] 6$
7	Jen takes five minutes to ride her bike to school and seven minutes to ride back home. If the distance between home and school is four-tenths of a mile, in miles per hour, what is her average rate for the two combined bike rides?	4 [mph]
8	Of six hundred people surveyed, one-fourth of the two hundred people who reported owning an Xbox also own a PlayStation. If each person surveyed owns an Xbox, a PlayStation, or both, how many own a PlayStation?	450
9	There are five thousand two hundred and eighty feet in a mile. A furlong is one-eighth of a mile. How many feet are in three furlongs?	1980 [feet]
10	In inches, what is the perimeter of a square whose area is two hundred and twenty-five square inches?	60 [inches]

# "Math Is Cool" Masters — 2023-24

7th/8<sup>th</sup> Grade — April 27, 2024

**Key**

## COLLEGE BOWL EXTRA PROBLEMS

#	Problem	Answer
1	What integer between thirty and forty-five has exactly nine positive integer factors?	36
2	How many integers between one hundred and two hundred have a ones digit that is a non-zero multiple of three?	30 [integers]
3	What is one thousand and one times two hundred and two?	202202
4	A fair coin is flipped and then a pair of standard six-sided dice are rolled. As a reduced common fraction, the probability that the result is heads followed by a sum of three is $A$ over $B$ . What is $A$ plus $B$ ?	$[A + B =] 37$
5	In square centimeters, the surface area of a right circular cylinder with radius two centimeters and height ten centimeters is $A\pi$ . What is $A$ ?	$[A =] 48$
6	Solve the equation for $X$ : five $X$ minus thirteen equals two $X$ plus twenty-six	$[x =] 13$
7	On the coordinate plane, find the distance in units between the points two comma negative one and eight comma seven.	10 [units]

# Proctoring Overview

You will receive a room packet envelope with the schedule and College Bowl rotations on the front. Each room packet includes:

- 1) the proctor instructions and the general instructions that you will be reading,
- 2) the proctor question/answers packet (this needs to be carefully controlled), and
- 3) sets of Mental Math, Individual, Multiple Choice, Team, and Triple Jump test materials.

(If not in the room packet, the proctor supervisor will provide blank scratch paper.)

When you receive the room packet, count to ensure that you have the correct number of tests for each event (16 Mental Math & Individual, 4 of each of the team events).

## Key Points

- Act professional; focus on what you are doing.
- Your job is to proctor the students; that is, you administer tests, give time warnings, & monitor students for proper test taking behavior to ensure competition integrity and avoid issues like failing to put answers on the answer sheet.
- The proctor packet has Mental Math and College Bowl questions/answers. Keep the packet secure! Avoid opportunities for competitors to see the tests or answers.
- Student/school names and team numbers are critical on the answer sheets. Make sure that students fill out such identifying information.
- Keep track of time, and provide appropriate time warnings. Keep to the schedule as close as possible. Wait between events, if needed.
- Read & know the rules—competitors & spectators will, and they will call you on it.
- On questions that you read, read smoothly, enunciate clearly, and don't read too fast.
- If unsure of how to deal with an issue/question/concern, flag down the proctor supervisor and ask.
- Be respectful of your classroom — leave it tidy and arranged exactly as you found it. We don't want any displeased teachers!!
- Use the quick-reference guide on the next page for room setup and key information.

## Schedule

*Each of the 6 events includes about 5 minutes at the start for reading instructions or rearranging the room.*

9:15 - 9:45	Coaches register (Entrance)	12:00 – 12:35	Lunch break
9:45 – 9:55	Orientation (TBD)	12:40 – 12:55	College Bowl #1
9:55 – 10:00	Students go to testing rooms	12:55 – 1:05	College Bowl #2
10:00 – 10:15	Mental Math	1:05 – 1:15	College Bowl #3
10:15 – 10:55	Individual Test	1:15 – 1:25	College Bowl #4
11:00 – 11:20	Team M.C. Test	1:25 – 1:35	College Bowl #5
11:20 – 11:40	Team Test	1:35 – 1:45	College Bowl #6
11:40 – 12:00	Triple Jump	2:00	Awards Ceremony (TBD)

### 1. Mental Math

**Configuration:** Students at individual desks spread out in the classroom. Alternating desks, students not next to teammates.

**Scheduled Time:** 10-10:15 AM (read instructions & test)

**Duration:** 30 seconds per question maximum (beginning after the 2<sup>nd</sup> reading)

**Give Time warning at:** 5 seconds

**Number of questions:** 8 (all students do the same questions)

**Proctor Actions:** Read each question twice, reading clearly and not too fast. Start the 30 second clock after the 2<sup>nd</sup> reading.

**Key Points:** Start by reading "General Instructions" then Mental Math instructions. Make sure everyone writes their name, school & team number on the answer sheet. No talking allowed. Except for the answer, no writing allowed. Collect answer sheets and organize by team number, then alphabetically by first name of competitor, & staple sheets for the same team together.

### 2. Individual Test

**Configuration:** Students at individual desks; same arrangement as for Mental Math.

**Scheduled Time:** 10:15 AM (read instructions),  
10:20 - 10:55 (test)

**Duration:** 35 minutes

**Give Time warning at:** 5 minutes & 30 seconds

**Number of questions:** 40

**Proctor Actions:** Ensure appropriate test-taking behavior. Prep for next event (or furtively read College Bowl questions to yourself).

**Key Points:** Read "Individual Test" instructions. Make sure everyone writes their name, team number, school, proctor name, & room number down on the answer sheet. Collect answer sheets, organize by team, then alphabetically by first name of competitor, and staple sheets for same team together.

### 3. Team Multiple Choice Test

**Configuration:** Groups of 4 desks, with the groups spread out in the classroom.

**Scheduled Time:** 11:00 AM (read instructions),  
11:05 - 11:20 AM (test)

**Duration:** 15 minutes

**Give Time warning at:** 5 minutes & 30 seconds

**Number of questions:** 10

**Proctor Actions:** Ensure appropriate test-taking behavior. Prepare for next event.

**Key Points:** Read Mult. Choice instructions. Students can talk quietly & work together.

### 4. Team Test

**Configuration:** Groups of 4 desks spread out in the classroom (same as Team Mult. Choice).

**Scheduled Time:** 11:20 AM (read instructions),  
11:25 - 11:40 (test)

**Duration:** 15 minutes

**Give Time warning at:** 5 minutes & 30 seconds

**Number of questions:** 10

**Proctor Actions:** Ensure appropriate test-taking behavior. Prepare for next event.

**Key Points:** Read Team Test instructions. Need to have school & team number on answer sheet. Students can talk quietly & work together.

### 5. Triple Jump

**Configuration:** Groups of 4 desks spread out in the classroom.

**Scheduled Time:** 11:40 AM (read instructions),  
11:45 - 12:00 PM (test)

**Duration:** 15 minutes

**Give Time warning at:** 30 seconds and 5 seconds before each of three submittals.

**Number of questions:** 10

**Proctor Actions:** Ensure appropriate test-taking behavior. Collect Submittals #1, #2 and #3 at 5, 10 and 15 minutes.

**Key Points:** Read Triple Jump instructions. Need to have school & team number on answer sheets. There are THREE answer sheets and submittals. Students can talk quietly & work together

### 6. College Bowl

**Configuration:** Row of 9 desks (side by side) at the front of the room (CBA device on center desk).

**Scheduled Time:** 12:40 PM (read instructions),  
12:45 - 1:45 PM (test)

**Duration:** 45 seconds per question (30 seconds per question if there is only one team, who will be only going against the clock)

**Give Time warning at:** 5 seconds

**Number of questions:** 10 per round, 6 rounds total

**Proctor Actions:** Read each question twice, reading clearly and not too fast. Start 45 (or 30) second clock after the 2<sup>nd</sup> full reading. Mark tally on white board as questions are answered and transfer the numeric total to the score sheets.

**Key Points:** Event is collaborative, talking is allowed. For a wrong answer, just say, "That is incorrect." (no verbal/visual clues that could be interpreted by the other team to arrive at an answer).



# Summary of MIC Proctoring

(for proctors to read to themselves)

Pass out materials (answer sheet/test packets, scratch paper) for the current event to individuals or teams (as appropriate) so they can fill in the name, school, and team number information (very important!). Tell students to not lift the cover sheet or turn over the paper until you give the signal to start. Read the general instructions as the first item at the beginning of the competition (before Mental Math). Read the event-specific instructions just prior to each event and ask if there are any relevant questions. After reading the instructions, you can signal students to begin. Make sure one proctor is watching the time and giving appropriate time warnings (e.g., "five minutes remaining"). At the end of the event, tell competitors to stop work. Collect, sort, & staple the answer sheets (as appropriate) and keep them secure until handed off to a runner.

For the Mental Math/Individual tests, arrange students scattered throughout the classroom with **no student next to another student from their own school**. For the team tests, students will be in groups of 4 desks. College Bowl will require a line of 9 desks side-by-side across the front of the classroom.

For College Bowl, place the College Bowl apparatus (CBA) on a central desk in the line of desks at the front (4 desks on either side of the central one). One proctor will likely need to hold the CBA in place during the College Bowl rounds. Turn the apparatus on by depressing the button or flipping the dip switch. Students may try out the CBA prior to the 1<sup>st</sup> question. Note: while one light is blinking, the other light is locked out. There is no need to "reset" the device, just let the light finish blinking and it is ready to go.

Do not read the answer for College Bowl when you read the question (they are both on the same page). In College Bowl, if an incorrect answer is given, simply say "That is incorrect" and do not give any other cues about the answer (e.g., don't say "sorry, you were close" or exhibit interpretable body language). If both teams fail to supply a correct answer, announce what the correct answer was.

If there is an irregularity (i.e., lack of honesty, poor sportsmanship), make a note of the circumstances, flag the answer sheet, and report the issue to the proctor supervisor.

At the end of the day, return the desks to their original arrangement, recycle any unwanted test materials & used scratch paper, erase any marks you made on the whiteboard, and generally make sure the classroom is tidied up. Return the CBA, the room packet envelope, the proctor instructions, the contest rules packet, the proctor packet of questions, extra scratch paper, and unused test material to the proctor supervisor.

# Detailed Instructions for Proctors

## Grades 4-8

NO CALCULATORS ALLOWED ON ANY TESTS!

1. Check to make sure you have everything in your packet.
  - A. **Mental Math:**
    1. 16 - colored Mental Math answer sheets
    2. Mental Math questions with answers (in the Proctor Packet)
  - B. **Individual Test:** 16 individual tests, with colored answer sheets attached
  - C. **Team Multiple Choice Test:** 4 team multiple choice packets (stapled), each containing 4 tests plus one colored answer sheet on top
  - D. **Team Test:** 4 team test packets (stapled), each containing 4 tests plus one colored answer sheet on top
  - E. **Triple Jump:**  
4 team test packets (stapled), each containing 4 tests plus three colored answer sheets on top (one per submittal).
  - F. **College Bowl:**
    1. 4 - College Bowl score sheets
    2. College Bowl questions - 6 rounds (in the Proctor Packet)
  - G. Scratch paper (to be handed out as needed, but try not to waste it)
  - H. Electronic College Bowl Apparatus (CBA; usually distributed at dinner break)

ALL **COLORED** ANSWER SHEETS WILL BE COLLECTED BY YOU AND WILL BE TAKEN TO THE SCORING ROOM (by RUNNERS) AS SOON AS THEY ARE FILLED OUT BY COMPETITORS. COMPETITORS CAN KEEP ALL OF THE WHITE SHEETS, IF THEY WOULD LIKE (OTHEWISE COLLECT THEM FOR RECYCLE).

If you are missing anything, you can go get it before the opening ceremony. After the opening ceremony, contact the proctor supervisor/scoring room.

2. Take a photo or draw a picture on the whiteboard of how the classroom is laid out (so that it can be returned to its original configuration following the competition). Then set up the classroom desks for the first event (Mental Math).

**Respect the teacher whose room you are using. Do not touch their computer or other items. Do not erase anything on their board. Leave the room tidy & in the exact original layout.**

### **Mental Math**

3. Arrange desks in a configuration suitable for individual testing (rows/grid of desks all facing forward, students in separated/alternating desks).
4. Put the Mental Math answer sheets face up on the desks such that students are spread out. Wait for students to arrive. You can fill out the proctor name and room

number (and perhaps team numbers) on all blank answer sheets, if you like. Read over the questions so you will be prepared to read them out loud.

5. After students sit down, check to make sure that no one from the same team is seated next to each other (i.e., "Team xxx, raise your hands."). Ask them to move, if needed.
6. **Check to make sure that students put their full name, school name, team number, and room number on their answer sheet and that the information is legible.**
7. Read the "GENERAL INSTRUCTIONS" (in the Proctor Packet) to the students. Then, read the "MENTAL MATH" instructions (in the Proctor Packet) to the students.
8. Begin the testing. Read each of the eight Mental Math questions to all of the students in the room, per the instructions.
9. At the conclusion of Mental Math, collect the answer sheets. Organize the answer sheets by team number, then alphabetically by first name of competitor. Staple each team's set of four answer sheets together. Promptly hand the packets of answer sheets to your runner for conveyance to the scoring room.

### **Individual Test**

10. The seating configuration will remain unchanged (no swapping seats).
11. Hand out Individual Test packets with the colored blank answer sheet facing up. **Check to make sure that students put their full name, school name, team number, and room number on their answer sheet and that the information is legible.**
12. Read the "INDIVIDUAL TEST" instructions (in the Proctor Packet) to the students and begin the testing at the appointed time.
13. While students are taking the Individual Test, monitor the students for proper test-taking behavior and watch the time to provide 5-minute and 30-second warnings. Make sure students are writing answers on the answer sheet (not the test question pages). During this time you can also get the Individual Multiple Choice tests ready, read through the rules of subsequent events, and (carefully/secretively) look ahead to review the College Bowl questions (i.e., to avoid stumbling over the wording when it comes time to read the questions aloud). You will have observers in the room watching the College Bowl rounds, so make sure you understand the rules, how timing works, etc.
14. At the conclusion of Individual Test, collect the answer sheets. Organize the answer sheets by team number, then alphabetically by first name of competitor. Staple each team's set of four answer sheets together. Promptly hand the packets of answer sheets to your runner for conveyance to the scoring room. Students may keep or recycle their test question packets.

## Team Multiple Choice

15. Change the room set-up to groups of 4 desks together so students can work as a team.
16. Hand out the tests and have teams fill out the top portion of the answer sheet. **Check answer sheets to make sure they are filled out correctly (school, team #, etc.).**
17. Read the "TEAM MULTIPLE CHOICE" instructions (in the Proctor Packet) to the students and begin the testing at the appointed time.
18. Monitor the students for proper test-taking behavior (talking is allowed), watch the time, and provide 5-minute and 30-second warnings. While students are taking the Team Multiple Choice test, get the Team Tests ready.
19. At the conclusion of the test, collect the answer sheets & hand them off to the runner.

## Team Test

20. Keep the same seating arrangement in groups of four. Hand out the Team Test packets and have teams fill out the information at the top of the colored answer sheet. **Check the answer sheets to make sure they are filled out correctly (school, team #, etc.).**
21. Read the "TEAM TEST" instructions (in the Proctor Packet) to the students and begin the testing at the appointed time.
22. Monitor the students for proper test-taking behavior (talking is allowed), watch the time, and provide 5-minute and 30-second warnings.
23. At the conclusion of the test, collect the answer sheets & hand them off to the runner.

## Triple Jump

24. Keep the same seating arrangement in groups of four. Hand out the Triple Jump Test packets and have teams fill out the information at the top of EACH OF THE THREE colored answer sheet. **Check the answer sheets to make sure they are filled out correctly (school, team #, etc.).**
25. Read the "Triple Jump TEST" instructions (in the Proctor Packet) to the students and begin the testing at the appointed time.
26. An Answer Sheet must be submitted every 5 minutes (labeled: Submittal #1, Submittal #2, Submittal #3). Give time warning at 30 seconds and 5 seconds prior to each submittal. Collect the submittals promptly at 5 minutes, 10 minutes and 15 minutes.
27. At the conclusion of the test, staple the three answer sheets for each team together in order: Submittal #1 (top), #2, #3 (bottom) & hand them off to the runner.

28. At the conclusion of the Triple Jump, release the students for their break. If there is anything left (i.e., answer sheets) that should have been taken to the scoring room, give those to the runner or have a proctor take it to the scoring room now.
29. Set up your room for the College Bowl rounds and tidy up the room before you go to break. Set up a line of 9 desks side by side facing the front of the room. One team will be on each side (doesn't matter which) and the College Bowl apparatus will be stuck down on the desk in the middle. Another row of 8 desks should be set up in the middle of the room for the two teams not competing in a round. Other desks should be moved to the back of the room in an orderly fashion for the spectators.
30. Take your packet of College Bowl questions with you during break to keep them secure! Do not leave them in the room!

### **Dinner Break**

31. AT BREAK — Eat dinner in the proctor room. Pick up your College Bowl apparatus (CBA) at this time. If you haven't already, you may want to read over the College Bowl questions to make sure you will be able to pronounce everything properly. Return to your room in time to place the CBA in position.

### **College Bowl Rounds**

32. Place the CBA on the middle desk of the line at the front of the room (you may want to moisten the suction cups with a film of water). One proctor may need to hold the device down (and do timing). Do not press the button to "reset" the CBA (it's an on/off switch).
33. You will have the same teams that were previously in the room for the duration of all College Bowl rounds — if you have an extra/different team, they are in the wrong room and can be disqualified if they hear the questions! Help get them to the correct room.
34. Fill out the score sheets for each team in your room with their school name and team number. Call up the first 2 teams according to the sequence on the room envelope.
35. You will be reading Round #1 questions to two teams while the other two teams (and any spectators) wait in the back of the room out of line of sight of the competitors. Refer to the College Bowl schedule (on your room envelope) to see which two teams compete in each round. If a round only has one team, they will be competing against the clock and thus will have 30 seconds to answer, not 45 seconds. Record the final scores for each team on their score sheets (which you hold on to) after each round. Rounds 2-6 work the same way. Refer to the schedule to make sure the correct teams are competing at the correct time. Don't get ahead of schedule (or behind, for that matter!). If you finish a round early, please wait until the appointed time to start the next round. If you have any problems (including anyone questioning the rules or a decision made by a proctor) contact the proctor supervisor.

36. Who is keeping score? Who is keeping track of the time? YOU ARE !!!
37. Read the "COLLEGE BOWL" instructions (in the Proctor Packet) to all the students (just one time), then begin the testing for each round at the appointed times.
38. If you mis-read a question, replace it with one of the extra questions.
39. If a parent/coach/student protests an answer, make a note of the situation (the test, the problem number, who answered, what their answer was, etc.) and kindly state that the coach should bring up the issue with the contest director. Proceed as normal, scoring the question based on the answer key.
40. At the conclusion of all College Bowl rounds, get the score sheets promptly to the scoring room (either yourself or via a runner).
41. Release your group to the awards ceremony no earlier than 7:45 PM to avoid causing a disruption to other rooms. Have students help re-set the room.
42. At the end of the day, return the desks to their original arrangement, collect all scratch paper, erase any marks you made on the whiteboard, and generally make sure the classroom is tidied up. Return the College Bowl apparatus, proctoring envelope, and residual material to the proctor supervisor.

# General Instructions

- Good sportsmanship is expected throughout the competition by all involved (competitors and observers). Display of poor sportsmanship will result in disqualification.
- Competitors may not use calculators or any other aids on any portion of this contest.
- Unless stated otherwise: Note: for 2023 tests, all answers are integers.
  - Express all rational, non-integer answers as common fractions, except in problems dealing with money, where you should give the answer as a decimal rounded to the nearest cent.
  - For fifth grade and up, all fractions and ratios must be reduced to simplest form, all radicals must be simplified, and all denominators must be rationalized.
  - Do not round or approximate answers. Leave answers in terms of  $\pi$  or other irrational quantities (e.g.,  $\sqrt{2}$ ), where applicable.
- Units are not necessary as part of your answer, unless it is a problem that deals with time, in which case, AM or PM is required. However, if you choose to use units, they must be correct.
- Record all answers on the colored cover sheets in the answer column only.
- **Be sure that the student name, school, team number, etc. has been filled out at the top of each answer sheet.**
- Tests will be scored as a 0 if answers are not recorded correctly on the answer sheets.
- Blank answer sheets and answer sheets with no name will be scored as a 0.

# Mental Math Instructions

All students in the room will concurrently be asked the same eight questions in this individual test. When it is time to begin, the proctor will read the first question twice. You may not do any writing or talking while arriving at a solution. Once you have a solution, record it on the sheet in front of you. **You may not change or cross out answers once you have written an answer down. If there are eraser marks, write-overs, or crossed-out answers, they will be marked wrong.** Once all students have laid their pencils on the

desk, another question will be asked. If a student doesn't lay his or her pencil down, the maximum wait time is 30 seconds after completion of the second reading of the question before the next question is read. You may continue to work on a problem (in your head) while the next question is being read. The raw score is 1 point per correct answer.

## Individual Test Instructions

You will have 35 minutes to work on the Individual test, which consists of 40 questions. When you are prompted to begin, tear off the colored sheet and begin testing. Make sure your name and school are recorded on the answer sheet. The first 30 questions are worth two points each and questions 31-40 are worth 3 points each. Record your answers on the score sheet. No talking during the test. You will be given a 5 minute warning.

## Team Multiple Choice Instructions

You will have 15 minutes to answer 10 multiple choice questions as a team. This test is the only test where you will be penalized for incorrect responses. You will receive two points for a correct letter response, zero points for leaving it blank, and minus one point for an incorrect response. When you are prompted to begin, tear off the colored answer sheet, pass out a copy of the test to each team member, and begin testing. **ONLY a letter response should be listed as an answer on this answer sheet.**

## Team Test Instructions

You will have 15 minutes to answer 10 questions as a team. When you are prompted to begin, tear off the colored answer sheet and give a copy of the test to each of your team members and begin testing. Each problem is scored as a 1 or 0. Record all answers on this colored answer sheet.



# Triple Jump Instructions

You will have 15 minutes to answer 10 questions as a team. However, you will submit a set of answers every 5 minutes. Notice that your answer sheets are labeled Submittal #1 (to be submitted after 5 minutes), Submittal #2 (to be submitted after 10 minutes) and Submittal #3 (to be submitted after 15 minutes). Each problem is scored as a 1 or 0 on each of the three submittals, for a total of 30 points. Answers that are written on one submittal sheet do NOT carry over to the next submittal sheet - they need to be entered again. You may change your answer for a question from one submittal to the next, if you feel that your previous answer was incorrect.

# College Bowl Instructions

## **Read these to the competitors before the first round:**

To maintain the integrity of the competition, spectators must stay in this room during a round of College Bowl questions. Once all readings for a round have been completed, you may leave.

All competitors must be facing the front of the room in one row. Teams not competing in the current round need to be behind the front row and in front of the spectators. All spectators need to be behind the competitors at the back of the room.

A maximum of ten questions per round will be scored. It is OK for both teams to score the same number of points! The proctor will record the points earned on each team's score sheet, which is retained by the proctor.

You may use scratch paper and pencil. You may talk with your team members while arriving at a solution.

An Electronic College Bowl Apparatus (CBA) will be used to identify the team who is first to have an answer.

During these rounds, each question will be read twice and a maximum time of 45 seconds after the second reading of the question is completed will be allowed for a team to answer. If a team buzzes in after the second reading and gives an incorrect response, the other team has the remainder of the 45 seconds to respond. A team is allowed only one attempt at buzzing in and answering per question. You may interrupt (buzz in) while a question is being read, however, if you do, the proctor will stop reading, and an immediate response is needed. If the correct response is given, the proctor will proceed to the next question. Otherwise, the question will be re-read for the other team, making sure it has two full readings. If an immediate response is not given after a team buzzes in, their lack of an answer in a timely manner is considered incorrect. In the event that only one team is competing in a round (i.e., one team is absent), the team competing will have a maximum of 30 seconds after the completion of the second reading in which to buzz in. The proctor will give a 5-second time warning.

Wait to be acknowledged by the proctor before giving an answer. This avoids the situation of blurting out an answer when the other team buzzed in first.

If two students from the same team answer at the same time with different answers, the answer will be considered incorrect.

If a problem arises with one of the questions, an extra question will be asked to replace that question.

If the round finishes early, you need to stay in the room for the remaining time.

# **Mental Math Questions**

## **College Bowl Questions/Answers**