

“Math is Cool” Masters -- 2022-23

6th Grade

Mental Math Solutions

6th	Answer	Solution
1	60 [%]	<p>The probability of rain tomorrow is two fifths. As a percent, what is the probability that it will not rain tomorrow?</p> $1 - 2/5 = 3/5 = 60\%$
2	20 [minutes]	<p>Jen rides her bike at an average rate of nine miles per hour. How many minutes does it take her to ride for three miles?</p> $9 \text{ miles in } 60 \text{ minutes} = 3 \text{ miles in } 20 \text{ minutes}$
3	12 [inches]	<p>The perimeter of a regular octagon is ninety-six inches. In inches, what is the length of one of the sides of the octagon?</p> $96/8 = 12$
4	0 [prime numbers]	<p>How many positive two-digit prime numbers have a five as their units digit?</p> <p>Any number with 5 as the units digit is divisible by 5 and therefore, not a prime number.</p>
5	4 [gum drops]	<p>A jar has a mix of ten red gum drops, fifteen green gum drops, and twelve yellow gum drops. Except for their color, all of the gum drops are identical. How many gum drops must be pulled from the jar, without looking, to guarantee two gum drops of the same color?</p> <p>On the first three draws it is possible to get one of each color. On the fourth draw there will have to be a matching pair.</p>
6	10 [eggs]	<p>A cake recipe calls for 3 cups of flour and 4 eggs. If the recipe is scaled up proportionately, how many eggs will be needed if seven and one-half cups of flour are used?</p> $(15/2) * 4/3 = 10$
7	25	<p>What is the mean of two to the first power, three to the second power, and four to the third power?</p> $2^1 + 3^2 + 4^3 = 2 + 9 + 64 = 75 \text{ and the mean is } 75/3 = 25$

8	[A + B =] 21	<p>As a reduced common fraction, the ratio of positive three-digit multiples of twenty to positive three-digit integers is A over B. What is the value of A plus B?</p> <p>100 to 980 = $20 * 5$ to $20 * 49$ makes 45 multiples of 20 and 100 to 999 is 900 three-digit multiples, so the ratio is $45/900 = 1/20$ and $1 + 20 = 21$</p>
----------	--------------	---

“Math is Cool” Masters -- 2022-23
6th Grade
Individual Test Solutions

6th	Answer	Solution
1	60	Evaluate: $110 + 130 + 150 + 170 - 500$ $110 + 130 + 150 + 170 - 500 = 60$
2	294	What is the sum of the next three numbers in the following arithmetic sequence? $13, 30, 47, 64, \underline{\quad}, \underline{\quad}, \underline{\quad}$ $81 + 98 + 115 = 294$
3	6 [ways]	A room has exactly three doors. In how many ways can a person enter the room by one door and leave the room by a different door? $3 * 2 = 6$
4	40 [%]	What percent of 175 is 70? $70/175 = p/100, p = 40$
5	[x =] 16	Solve for x: $8x + 103 = 231$ $8x + 103 = 231 \rightarrow 8x = 128 \rightarrow x = 16$
6	245	What is the largest positive integer factor of the number 735, other than 735? $735 = 3 * 245$
7	76	Mariah's scores in her last three rounds of golf were 81, 77, and 78. What score would she need on her next round to lower the mean score for these four rounds to 78? $78 * 4 = 312, \text{ and } 312 - (81 + 77 + 78) = 76$
8	10 [minutes]	A racecar drives at an average speed of 120 miles per hour. With this average speed, how long, in minutes, would it take the car to complete ten laps on a 2-mile track? 10 laps on a 2-mile track makes a total of 20 miles and 20 is $1/6$ of 120, and $1/6$ of an hour is 10 minutes.
9	450 [seconds]	How many seconds are in 7 and a half minutes? $7 * 60 + 30 = 450$
10	[A/B =] 25 [%]	A 3-inch by 3-inch square has area A and a 6-inch by 6-inch square has area B. What is the value of A/B as a percent? $A = 3 * 3 = 9$ and $B = 6 * 6 = 36$ and $9/36 = 25\%$

11	1599	What is the product of 41 and 39? $(40 + 1)(40 - 1) = 1600 - 1 = 1599$
12	12	My number is doubled. The result is then divided by 3 and then 10 is added. If the resulting number is 18, what is my number? $2x/3 + 10 = 18 \rightarrow 2x/3 = 8 \rightarrow 2x = 24 \rightarrow x = 12$
13	[A + B =] 11	A jar has 12 blue marbles and 16 green marbles. As a reduced common fraction, the probability that a randomly selected marble is not blue is A/B. What is the value of A + B? $P(\text{not blue}) = 16/28 = 4/7$ and $4 + 7 = 11$
14	[P =] 7	Let P represent a prime number. Let Q represent a positive even integer. What is the largest possible value of P, such that $P + Q = 11$? $2 + 9 = 11$, but 9 is not prime, and $4 + 7 = 11$, so the largest possible value of P is 7
15	72 [inches]	An equilateral triangle has sides of length 8 inches. The length of one side is multiplied by 2, the length of another side is multiplied by 3 and the length of the third side is multiplied by 4 to make a new triangle. What is the number of inches in the perimeter of the new triangle? $8(2) = 16$, $8(3) = 24$, $8(4) = 32$, and $16 + 24 + 32 = 72$
16	16	What is the largest possible median in a set of nine distinct positive integers all less than 21? The set with the largest median is the set 12, 13, 14, 15, 16, 17, 18, 19, 20, and the median is 16.
17	288	What is the greatest product of any two distinct integer factors of 24? The two largest factors of 24 are 24 and 12 and $24 \cdot 12 = 288$
18	[\$] 90 [dollars] or [\$] 90.00 [dollars]	Let D represent the number of dollars Jen has that she wants to use to purchase concert tickets. If she tries to purchase two tickets, she will be short by 30% of the total cost. If she purchases one ticket, she will have \$36 left over. In dollars, what is the cost of one ticket? $2C(.7) = D$ $D = C + 36$ $1.4C = C + 36$ $0.4C = 36$ $C = 90$

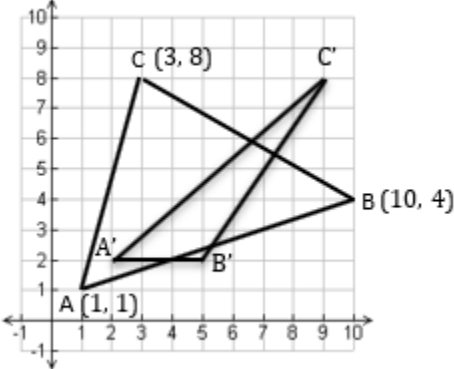
<p>19</p>	<p>4 [sheets]</p>	<p>The cost for a first-class letter (envelope and contents) sent through the USPS is 63 cents for up to 1 ounce. On average a standard business envelope weighs 0.238 ounces and a piece of 8.5" x 11" paper weighs 0.1696 ounces. How many full sheets of paper can go in a standard business envelope before the letter exceeds 1 ounce?</p> <p>Round 0.1696 to 0.17 and 0.238 to 0.24. $1 - 0.24 = 0.76$, so the number of sheets inside the envelope needs to be less than 0.76. $0.17 * 4 = 0.68$ and $0.17 * 5 = 0.85$, so four sheets can go in the envelope without it exceeding 1 oz.</p>
<p>20</p>	<p>13 [ways]</p>	<p>How many ways are there to make 3 dollars with nickels and/or quarters?</p> <p>60N & 0Q, 55N & 1Q, 50N & 2Q, ..., 10N & 10Q, 5N & 11Q, 0N & 12Q, makes a total of 13 ways</p>
<p>21</p>	<p>9 [units²]</p>	<p>On a coordinate plane, the coordinates of the vertices of ΔABC are labeled as shown. The coordinates of A are each multiplied by two resulting in A', the coordinates of B are each divided by two resulting in B' and only the x-coordinate of C is multiplied by three resulting in C'. What is the area of $\Delta A'B'C'$ in square units?</p> <p>The resulting triangle is shown here and has a base of 3 and a height of 6, so the area is $3 * 6 / 2 = 9$.</p> 
<p>22</p>	<p>[C + D =] 26</p>	<p>A donkey takes 36 minutes to walk from point A to point B and the distance from point A to point B is $\frac{3}{4}$ of a mile. The donkey's average speed in miles per hour is C.D, where C is a single-digit integer and D is a two-digit integer. What is the value of C + D?</p> <p>$0.75 \text{ mi} = 36 \text{ min} \rightarrow 0.25 \text{ mi} = 12 \text{ min} \rightarrow 1.25 \text{ mi} = 60 \text{ min}$, which is 1.25 miles/hour, and $1 + 25 = 26$.</p>
<p>23</p>	<p>50 [%]</p>	<p>Each letter in the expression $\frac{A}{B} + \frac{C}{D}$, is replaced with one of the four digits 3, 4, 5, and 6, to make the largest possible sum and such that $A > C$. As a percent, what is B/A?</p> <p>$6/3 + 5/4 = 3.25$, and $6/4 + 5/3 = 3.1666 \dots$, so the first one is the largest and $B/A = 3/6 = 50\%$.</p>

24	7 [ways]	<p>Fern wants to make a sum greater than 40 by adding together some or all of the numbers in the following set: {1, 2, 3, 4, 5, 6, 7, 8, 9}. She can't use the same number more than once, and the order she adds the numbers in doesn't matter. How many different ways can she do this?</p> <p>$1 + 2 + 3 + \dots + 7 + 8 + 9 = 45$ is one way Leave out the 1, the 2, the 3, or the 4, makes four more ways Leave out the 1 and 2, or the 1 and 3, makes two more ways $1 + 4 + 2 = 7$</p>
25	165	<p>For the function, $f(n) = \frac{n(n-1)}{2}$, what is the sum of the ten function values resulting from integer inputs $n = 1$ through $n = 10$?</p> <p>$0 + 1 + 3 + 6 + 10 + 15 + 21 + 28 + 36 + 45 = 165$</p>
26	1728 [in ³]	<p>How many cubic inches are in one cubic foot?</p> <p>$12 * 12 * 12 = 1728$</p>
27	79	<p>What is the largest two-digit integer that has a remainder of 1 when divided by 3, a remainder of 3 when divided by 4, and a remainder of 4 when divided by 5?</p> <p>The smallest positive number that matches the description is 19, because it's in the following three lists: One more than multiples of 3: 1, 4, 7, 10, 13, 16, 19 Three more than multiples of 4: 3, 7, 11, 15, 19 Four more than multiples of 5: 4, 9, 14, 19 Then numbers that have this quality will repeat every 60, since 60 is the LCM of 3, 4, and 5, so $60 + 19 = 79$.</p>
28	[A + B =] 18	<p>Two cards are drawn from a standard deck without replacement. The probability as a reduced common fraction that the first card is an Ace and the second card is not a Face Card (Jack, Queen, or King) is A/B. What is the value of $A + B$?</p> <p>$4/52 * 39/51 = 1/13 * 39/51 = 3/51 = 1/17$, and $3 + 17 = 18$</p>
29	10 [minutes]	<p>It takes Biff 50 seconds to paint one board and it takes Eho 60 seconds to paint the same board. If Biff and Eho work together, how many minutes will it take them to paint twenty-two such boards?</p> <p>$1/50 + 1/60 = 1/x \rightarrow 6x + 5x = 300 \rightarrow x = 300/11$ seconds per board, so 22 boards would be $300/11 * 22 = 600$ seconds or 10 minutes.</p>

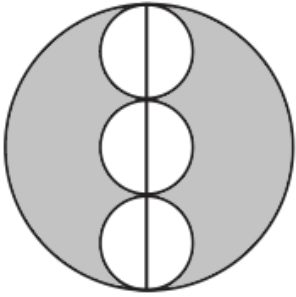
<p>30</p>	<p>[A =] 54</p>	<p>In the figure shown here, the diameter of the large circle is 18 centimeters. The three smaller circles are congruent, with their diameters coinciding with the diameter of the large circle. They are tangent to the large circle and each other as shown.</p>  <p>The area of the shaded region is $A\pi$ cm². What is the value of A?</p> <p>The shaded area is $9^2\pi - 3 * 3^2\pi = 81\pi - 27\pi = 54\pi$, so A = 54.</p>
<p>31</p>	<p>[A + B =] 46</p>	<p>A palindrome is an integer that reads the same forwards and backwards, such as 121. A 5-digit positive palindrome integer is divided by 111. As a reduced common fraction, the probability that the quotient is an integer and also a palindrome is A/B. What is the value of A + B?</p> <p>A five-digit number, when divided by 111111, will have either two or three number of digits.</p> <p>The only two-digit palindrome that gives five digits when multiplied by 111111 is 9999. However, $99 \cdot 111 = 1098999$, $111 \cdot 111 = 10989$, which is not a palindrome.</p> <p>Therefore, the result must have three digits and thus is of the form $100a+10b+a=101a+10b$, where $0 < a < 10$ and $0 \leq b < 10$.</p> <p>Multiplying this by 111 gives $11211a+1110b$. This can be arranged as $10000a+1000(a+b)+100(2a+b)+10(a+b)+a$.</p> <p>Then, $2a+b < 10$ (and $a+b < 10$) must be true so that the symmetry will not be broken by the addition from carrying over to the next digit.</p> <p>For $a=1$, there are eight possible values for b that satisfy the inequality: all integers between 0 and 7. For $a=2$, there are six possible values for b. For $a=3$, there are four possible values for b. For $a=4$, there are two possible values for b. For $a > 4$, there is no integer solution for b. Thus, there are in total 20 possibilities.</p> <p>There are 900 five-digit palindromes (one for each integer between 100 and 999). Thus, the probability that a five-digit palindrome is both divisible by 111 and still produces a palindrome when divided by 111 is $20/900=1/45$. The final answer is $1+45=46$.</p>
<p>32</p>	<p>3</p>	<p>What is the sum of the integer solutions of x in the following inequality?</p> $\frac{1}{30} < \frac{2x}{5} - \frac{1}{6} < \frac{9}{10}$ <p>$\frac{1}{30} < \frac{2x}{5} - \frac{1}{6} < \frac{9}{10} \rightarrow 1 < 12x - 5 < 27 \rightarrow 6 < 12x < 32 \rightarrow 6/12 < x < 32/12 \rightarrow 0.5 < x < 2.6666 \dots$, so the integer solutions are 1 and 2 and $1 + 2 = 3$.</p>
<p>33</p>	<p>648 [numbers]</p>	<p>How many positive three-digit base-9 numbers are there?</p> <p>Three-digit base-9 numbers range from 100_9 to 888_9, so there can be 9 units digits, 9 9s digits and 8 81s digits, and $9 * 9 * 8 = 648$.</p>

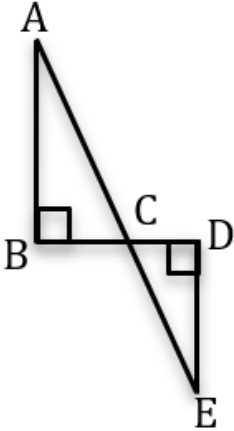
<p>34</p>	<p>[A + B =] 41</p>	<p>The given expression simplifies to a reduced common fraction in the form A/B. What is the value of A + B?</p> $2 + \frac{2}{2 + \frac{2}{2 + \frac{2}{3}}}$ $2 + \frac{2}{2 + \frac{2}{2 + \frac{2}{3}}} = 2 + \frac{2}{2 + \frac{3}{4}} = 2 + \frac{8}{11} = 30/11 \text{ and } 30 + 11 = 41$
<p>35</p>	<p>[P + Q =] 36</p>	<p>In the figure shown here, $\triangle ABC$ and $\triangle EDC$ are right triangles, $\triangle ABC \sim \triangle EDC$, and the ratio of $DE/BA = 0.75$. If $CD = 6$ cm and $DE = 15$ cm, then $AE = P\sqrt{Q}$ cm, where P is a single-digit prime number and Q is a two-digit prime number. What is the value of P + Q?</p>  <p>Since the ratio is 3:4 and $CD = 6$, that means $BC = 8$, so $BD = 14$. Also, if $DE = 15$, then $AB = 20$, so to calculate AE use the Pythagorean Theorem, $(15 + 20)^2 + 14^2 = AE^2 \rightarrow 35^2 + 14^2 = AE^2 \rightarrow 1225 + 196 = AE^2 \rightarrow 1421 = AE^2 \rightarrow AE = \sqrt{1421} = 7\sqrt{29}$, and $7 + 29 = 36$.</p>
<p>36</p>	<p>2 [n =]</p>	<p>Given that: $x + \frac{1}{x} = n$, and $x^2 + \frac{1}{x^2} = n$, where x and n are real numbers, find the sum of all possible values of n. Square the first equation:</p> $x^2 + \frac{1}{x^2} + 2 = n^2$ $x^2 + \frac{1}{x^2} = n^2 - 2$ <p>Equate the two expressions:</p> $n^2 - 2 = n$ $n^2 - n - 2 = 0$ $(n - 2)(n + 1) = 0$ $n = 2 \text{ or } -1$ <p>However, $n = -1$ is not a possible solution to the second given equation, since both x^2 and $1/x^2$ are positive and 'n' is a real number. Therefore the only solution is $n = 2$.</p>
<p>37</p>	<p>192 [minutes]</p>	<p>A water tank can be filled by pipe A in 4 hours and by pipe B in 6 hours. Pump A is turned on and then after two hours pump B is also turned on. How many minutes after pump A was turned on will the tank be full?</p> $(1/4)h + (1/6)(h - 2) = 1$ $3h + 2(h - 2) = 12$ $3h + 2h - 4 = 12$ $5h = 16$ $h = 3.2 \text{ hours} = 192 \text{ minutes}$

<p>38</p>	<p>$[A + B + C] = 18$</p>	<p>A, B, and C represent single digits in the following addition problem.</p> $ \begin{array}{r} A \ A \ A \\ B \ B \ B \\ + \ C \ C \ C \\ \hline B \ A \ A \ C \end{array} $ <p>If A, B, and C, are distinct positive integers, what is the value of $A + B + C$?</p> <p>The units column must add up to $10 + C$. It cannot add up to C, unless A and B are both 0, which is not allowed. This means that $A + B = 10$.</p> <p>The tens and hundreds columns must each add up to one more than the right-hand column, because a 1 got carried from the units column to the tens column, and from the tens column to the hundreds column. This means $A = C + 1$.</p> <p>B must equal 1, since a 1 also gets carried from the hundreds column to the thousands column. If $B = 1$, then A must equal 9, since $A + B = 10$, and $C = 8$, since $A = C + 1$.</p> <p>So, we have</p> $ \begin{array}{r} 9 \ 9 \ 9 \\ 1 \ 1 \ 1 \\ + \ 8 \ 8 \ 8 \\ \hline 1 \ 9 \ 9 \ 8 \end{array} $ <p>and $A + B + C = 18$.</p>
<p>39</p>	<p>$[A + B =] 249$</p>	<p>Whenever Tiger putts, he has an 80% chance of making the putt, independent of his previous putts. As a reduced common fraction, the probability of him making at least 1 of his next 3 putts is A/B. What is the value of $A + B$?</p> <p>$P(0 \text{ made putts}) = 1 * (1/5)^3$ $P(\text{at least 1 made putt}) = 1 - (1 * (1/5)^3) = 1 - 1/125 = 124/125$, and $124 + 125 = 249$</p>

<p>40</p>	<p>113</p>	<p>A 10th integer, A, when added to the following set, results in the median of the set equaling the mean of the set. What is the sum of all possible values of A? {13, 15, 21, 28, 33, 38, 42, 48, 51}</p> <p>The only number from 28 to 38, when inserted into the set, that makes the mean equal the median is 31.</p> <p>13,15,21,28,28,33,38,42,48,51, mean = 31.7 & median = 30.5 13,15,21,28,29,33,38,42,48,51, mean = 31.8 & median = 31 13,15,21,28,30,33,38,42,48,51, mean = 31.9 & median = 31.5 13,15,21,28,31,33,38,42,48,51, mean = 32 & median = 32 13,15,21,28,32,33,38,42,48,51, mean = 32.1 & median = 32.5 13,15,21,28,33,33,38,42,48,51, mean = 32.2 & median = 33 13,15,21,28,33,34,38,42,48,51, mean = 32.3 & median = 33.5 13,15,21,28,33,35,38,42,48,51, mean = 32.4 & median = 34 13,15,21,28,33,36,38,42,48,51, mean = 32.5 & median = 34.5 13,15,21,28,33,37,38,42,48,51, mean = 32.6 & median = 35 13,15,21,28,33,38,38,42,48,51, mean = 32.7 & median = 35.5</p> <p>There is one integer less than 28 and one integer greater than 38 that will cause the median and the mean to be equal. When the 10th number is less than 28, the median would be 30.5, which requires the sum of the 10 numbers to be 305. The tenth number would be $305 - (\text{sum of original 9 numbers}) = 305 - 289 = 16$</p> <p>When the 10th number is greater than 38, then median would be 35.5, which requires the sum of the 10 numbers to be 355. The tenth number in this case is $355 - 289 = 66$.</p> <p>$A = 16 + 31 + 66 = 113$</p>
------------------	------------	--

“Math is Cool” Masters -- 2022-23

6th Grade

Multiple Choice Solutions

6th	Answer	Solution
-----	--------	----------

REFER TO THE FOLLOWING INFORMATION FOR PROBLEMS #1 THROUGH #3.

The table shows the population of wolves and moose in Isle Royale National Park in Michigan from 1980 to 2019.

One of the two untitled histograms below represents the wolf data, and the other represents the moose data. On a histogram, the frequency of a bar indicates the number of times that the population was in the interval that corresponds with the bar. For example, if a bar has a frequency of 7, it means that there were 7 data values that fell within that data interval.

Year	# of Wolves	# of Moose	Year	# of Wolves	# of Moose
1980	50	664	2000	29	850
1981	30	650	2001	19	900
1982	14	700	2002	17	1000
1983	23	900	2003	19	900
1984	24	811	2004	29	750
1985	22	1062	2005	30	540
1986	20	1025	2006	30	385
1987	16	1380	2007	21	450
1988	12	1653	2008	23	650
1989	11	1397	2009	24	530
1990	15	1216	2010	19	510
1991	12	1313	2011	16	515
1992	12	1600	2012	9	750
1993	13	1880	2013	8	975
1994	15	1800	2014	9	1050
1995	16	2400	2015	3	1250
1996	22	1200	2016	2	1300
1997	24	500	2017	2	1600
1998	14	700	2018	2	1500
1999	25	750	2019	14	2060

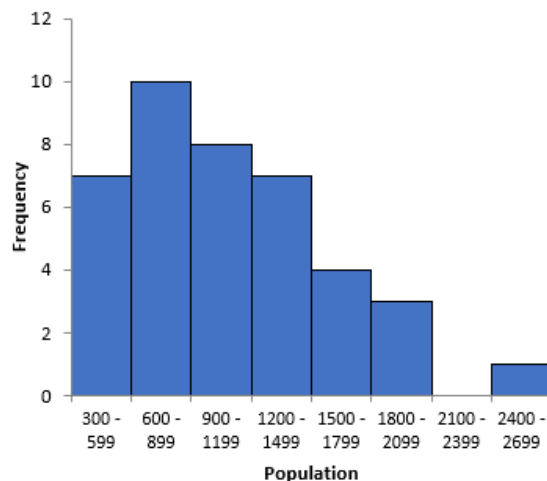
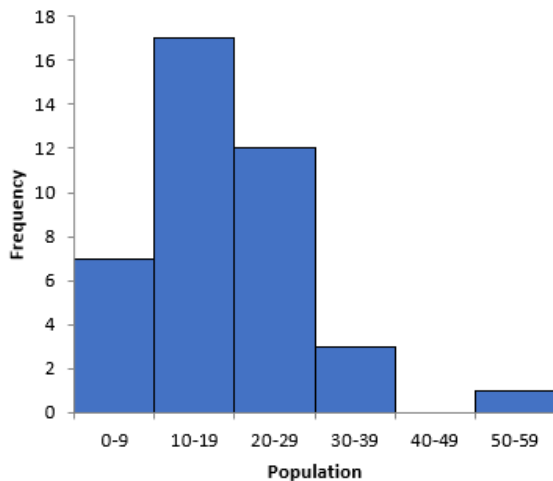

<p>1</p>	<p>E</p>	<p>During what year was the wolf population its highest during this 40-year period in Isle Royale National Park?</p> <p>A) 2006 B) 2005 C) 1995 D) 1981 E) 1980</p> <p>The wolf population was at its highest at 50 in 1980.</p>
<p>2</p>	<p>D</p>	<p>What is the sum of the three moose population numbers corresponding with the bar having frequency 3 and the one wolf population number corresponding with the bar with frequency 1 on their respective histograms?</p> <p>A) 492 B) 2490 C) 5742 D) 5790 E) 5838</p> <p>For moose, the bar with frequency 3 has the interval 1800 – 2099, so it includes 1800, 1880, and 2060. For wolves, the bar with frequency 1 has the interval 50 – 59, so it includes 50. $1800 + 1880 + 2060 + 50 = 5790$</p>
<p>3</p>	<p>A</p>	<p>The stem-and-leaf plot below is for the wolf data.</p> <pre> 0 2, 2, 2, 3, 8, 9, 9 1 1, 2, 2, 2, 3, 4, 4, 4, 5, 5, 6, 6, 6, 7, 9, 9, 9 2 0, 1, 2, 2, 3, 3, 4, 4, 4, 5, 9, 9 3 0, 0, 0 4 5 0 </pre> <p>If three numbers are randomly selected without replacement from the data set, what is the probability that they will each be the same number, in other words, one of the modes?</p> <p>A) 7/9880 B) 3/4940 C) 1/1976 D) 1/2470 E) 3/9880</p> <p>$P(\text{three 2s or three 12s or three 14s or three 16s or three 19s or three 24s or three 30s}) = 7 * P(\text{three 2s}) = 7 * \frac{3}{40} * \frac{2}{39} * \frac{1}{38} = 7 * \frac{1}{40} * \frac{1}{13} * \frac{1}{19} = \frac{7}{9880}$</p>

REFER TO THE FOLLOWING INFORMATION FOR PROBLEMS #4 THROUGH #6.

Figure A below is a 12 x 16 x 20-centimeter rectangular prism with a hole passing horizontally through its center that is also in the shape of a rectangular prism. The bases of the rectangular-prism-shaped hole are 8 x 9 centimeters and are in the same plane as the right and left faces of the large prism.

Figure A

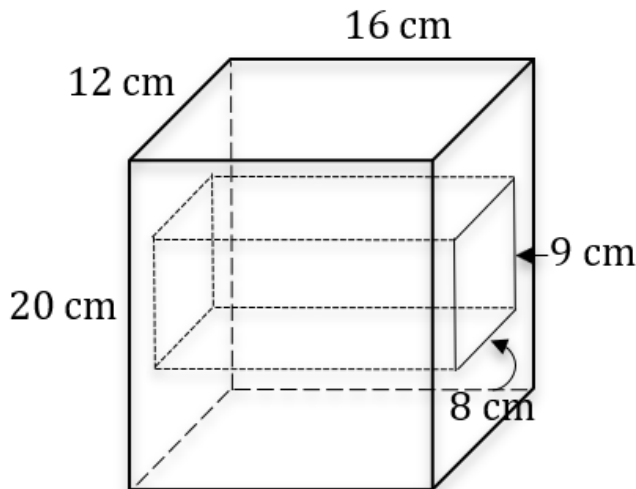

<p>4</p>	<p>C</p>	<p>What is the volume of the rectangular-prism-shaped hole in Figure A?</p> <p>A) 688 cm³ B) 864 cm³ C) 1152 cm³ D) 1440 cm³ E) 3840 cm³</p> <p>$8 * 9 * 16 = 1152$</p>
<p>5</p>	<p>B</p>	<p>Including edges on the interior and exterior of the rectangular-prism-shaped hole, what is the sum of the lengths of all the edges in Figure A?</p> <p>A) 340 cm B) 324 cm C) 308 cm D) 284 cm E) 260 cm</p> <p>$12 * 4 + 16 * 4 + 20 * 4 + 8 * 4 + 9 * 4 + 16 * 4 = 48 + 64 + 80 + 32 + 36 + 64 = 324$</p>
<p>6</p>	<p>C</p>	<p>Assume the interior faces of the rectangular-prism-shaped hole are part of the surface area of Figure A. What is the surface area of Figure A?</p> <p>A) 1152 cm² B) 1760 cm² C) 1904 cm² D) 2048 cm² E) 2120 cm²</p> <p>$16 * 12 * 2 + 16 * 20 * 2 + (12 * 20 - 9 * 8) * 2 + 8 * 16 * 2 + 9 * 16 * 2 = 384 + 640 + 336 + 256 + 288 = 1904$</p>

USE THE FOLLOWING INFORMATION TO SOLVE PROBLEMS #7 THROUGH #10.

In the three infinite sequences below, 9 is the first term in sequence A, and 1 is the first term in sequence B and in sequence C.

A: 9, 22, 35, 48, 61, 74, . . .

B: 1, 3, 6, 10, 15, 21, . . .

C: 1, 3, 9, 27, 81, 243, . . .

7	D	What is the sum of the next number in each of the three series? A) 874 B) 864 C) 854 D) 844 E) 834 $729 + 87 + 28 = 844$
8	C	What is the mean of the first 8 numbers in series A? A) 52.625 B) 54 C) 54.5 D) 55 E) 56.125 Since this is an arithmetic sequence, the median is the same as the mean, so $(48 + 61)/2 = 54.5$
9	E	Select the answer which gives the correct rule for each series, where n stands for the series of positive integers, 1, 2, 3, . . . A) A: $13n + 4$, B: $n(n-1)/2$, C: 3^{n-1} B) A: $9n + 13$, B: $n(n-1)/2$, C: 3^n C) A: $13n - 4$, B: $n(n-1)/2$, C: 3^n D) A: $13n$, B: $n(n+1)/2$, C: 3^n E) A: $13n - 4$, B: $n(n+1)/2$, C: 3^{n-1} $13(1) - 4 = 9$, $13(2) - 4 = 22$, $13(3) - 4 = 35$, etc. $1(1+1)/2 = 1$, $2(2+1)/2 = 3$, $3(3+1)/3 = 6$, etc. $3^{1-1} = 1$, $3^{2-1} = 3$, $3^{3-1} = 9$, etc.

10**B**

Let P represent the largest 3-digit integer in series A, let Q represent the largest 3-digit integer in series B, and let R represent the largest 3-digit integer in series C. Given the numbers P , Q and R , which of the following shows the ratio of prime numbers to composite numbers for the three values?

- A) 0:3 B) 1:2 C) 2:1 D) 3:0 E) 3:1

A: $13n - 4 < 1000 \rightarrow 13n < 1004 \rightarrow n < 77 \frac{3}{13}$, and $13(77) - 4 = 997 = P$

B: $n(n+1)/2 < 1000 \rightarrow n^2 + n - 2000 < 0$, if $n = 45$, then $n^2 + n - 2000 > 0$, if $n = 44$, then $n^2 + n - 2000 < 0$, so the largest 3-digit integer will be when $n = 44$, which is $990 = Q$

C: 729 is the largest 3-digit integer in this series, so $729 = R$

Only 997 is prime, so the ratio is 1:2

“Math is Cool” Masters -- 2022-23

6th Grade

Team Test Solutions

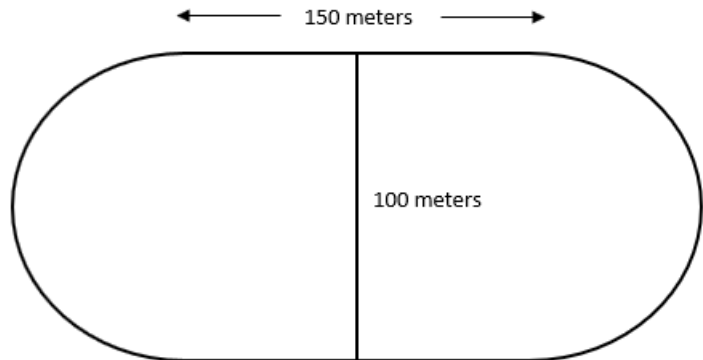
6th	Answer	Solution
1	29	Evaluate: $4(17 - 11) + 320/64$ $4(17 - 11) + 320/64 = 4(6) + 5 = 29$
2	252 [inches]	How many inches are in 7 yards? $3 * 12 * 7 = 252$
3	36	Let $a \bullet b = ab + ba$ (a times b plus b times a). What is the value of $3 \bullet 6$? $3 \bullet 6 = 3(6) + 6(3) = 18 + 18 = 36$
4	10 [apples]	If 4 apples cost the same as 12 bananas and 6 bananas cost the same as 1 pear, how many apples cost the same as 5 pears? $4a = 12b$ and $6b = p$, so $12b = 2p$ and $4a = 2p$ and $10a = 5p$, so the answer is 10.
5	[A + B =] 400	A track has two straight sections that are each 150 meters long and two semicircular ends, each with a diameter of 100 meters as shown below. In terms of π , the perimeter of the track is $A\pi + B$ meters. What is the value of $A + B$? The length of the two semicircular ends is 100π and the length of the two straight sections combined is 300, so the length of the track is $100\pi + 300$, and $100 + 300 = 400$. 

6	72 [days]	<p>Buzz is traveling to the Planet Zog, which is twenty-six light years away, and his spaceship travels thirteen light years every twenty-four days. A quarter of the way through the trip, he realizes he forgot his ray blaster at home and goes back for it. In days and from the moment he first leaves, how long does it take for Buzz to reach the Planet Zog?</p> <p>$26/13 = 2$, so $2 * 24 = 48$ is the number of days it would take without a delay. The delay is $(1/4)48 * 2 = 24$, so $48 + 24 = 72$.</p>
7	-9	<p>An arithmetic sequence can be described by the rule $2n + 1$, where n can be any integer. What is the sum of the three largest negative numbers in the sequence?</p> <p>$-1 + -3 + -5 = -9$</p>
8	<p>[A + B =]</p> <p>248</p>	<p>As a reduced common fraction, the probability that the product of any three randomly selected and not necessarily distinct single-digit positive integers is 12 is A/B. What is the value of $A + B$?</p> <p>Total possible outcomes equals $9 * 9 * 9 = 729$</p> <p>The 15 outcomes where the product is 12 include: (1,2,6), (1,6,2), (2,1,6), (2,6,1), (6,1,2), (6,2,1), (1,3,4), (1,4,3), (3,1,4), (3,4,1), (4,1,3), (4,3,1), (2,2,3), (2,3,2), (3,2,2)</p> <p>So, $A/B = 15/729 = 5/243$, and $5 + 243 = 248$</p>

9

22

[rectangles]

How many rectangles of any size are in the figure below?

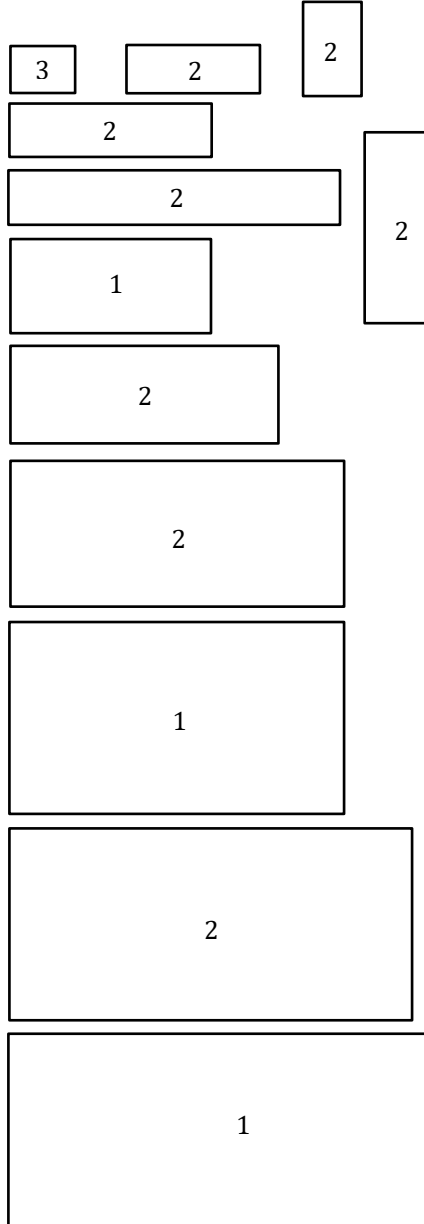
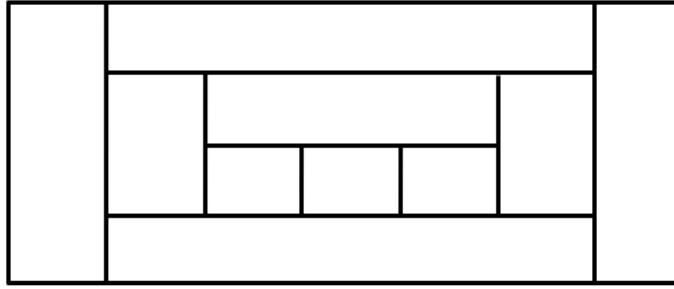

$$3 + 2 + 2 + 2 + 2 + 2 + 1 + 2 + 2 + 1 + 2 + 1 = 22$$

10**384**

Enrique's locker combination is a positive three-digit integer, where each digit is a unique number from 1 to 9 inclusive. One morning while opening his locker, Enrique realized that if he multiplied the three digits of the number together, the product would be exactly one-fourth of the number that is his locker combination. What is Enrique's locker combination?

Let the locker combination be ABC, where A = hundreds digit, B = tens digit, C = units digit. Can write an equation:

$$A \times B \times C = \frac{1}{4}(100A + 10B + C)$$

In other words, the product of the three digits equals one-fourth of the number itself.

Therefore, the number itself must be divisible by 4, meaning that the last two digits BC must be divisible by 4. There are no 0s in the number, and B and C are different digits. This narrows down the list of BC to: 12, 16, 24, 28, 32, 36, 48, 52, 56, 64, 68, 72, 76, 84, 92, and 96. A little trial and error can be used to try and get the magnitude of the number about right, and discover that the only number that works is 384, since $\frac{1}{4}(384) = 3 \times 8 \times 4 = 96$.

“Math is Cool” Masters -- 2022-23

6th Grade

Triple Jump Solutions

6th	Answer	Solution
1	429	<p>What is the next number in the following arithmetic sequence? 513, 492, 471, 450, _____</p> <p>The numbers are getting smaller by 21, so $450 - 21 = 429$.</p>
2	61	<p>Let A be the median of data set #1, let B be the median of data set #2, and let C be the median of data set #3. What is the mean of A, B, and C?</p> <p>Data set #1 - {11, 13, 17, 19, 23, 29, 31} Data set #2 - {25, 50, 75, 100, 125, 150, 175} Data set #3 - {1, 8, 27, 64, 125, 216, 343}</p> <p>$A = 19$, $B = 100$, and $C = 64$ and $(19 + 100 + 64)/3 = 183/3 = 61$</p>
3	60 [%]	<p>Riley eats $1/3$ of a cake and Beau eats $1/15$ of the cake. After this, what percent of the cake has not been eaten?</p> <p>$1 - 1/3 - 1/15 = 9/15 = 60\%$</p>
4	2 [ways]	<p>How many ways can you make 95 cents with dimes and/or quarters?</p> <p>7D & 1Q, 2D & 3Q makes 2 ways</p>

5	3 [bowl C]	<p>Bowl A contains 13 green skittles, bowl B contains 16 red skittles, and bowl C contains 15 orange skittles. Three green skittles are moved to bowl B, four red skittles are moved to bowl C and five orange skittles are moved to bowl A. Which bowl has the fewest skittles in it after these moves? Answer 1 for bowl A, 2 for bowl B, 3 for bowl C, or 4 if no one bowl has the fewest skittles.</p> <table border="1" data-bbox="696 495 1214 627"> <thead> <tr> <th></th> <th>Start</th> <th>Moves</th> <th>End</th> </tr> </thead> <tbody> <tr> <td>Bowl A</td> <td>13</td> <td>13 - 3 + 5</td> <td>15</td> </tr> <tr> <td>Bowl B</td> <td>16</td> <td>16 - 4 + 3</td> <td>15</td> </tr> <tr> <td>Bowl C</td> <td>15</td> <td>15 - 5 + 4</td> <td>14</td> </tr> </tbody> </table> <p>Bowl C has the fewest, so the answer is 3.</p>		Start	Moves	End	Bowl A	13	13 - 3 + 5	15	Bowl B	16	16 - 4 + 3	15	Bowl C	15	15 - 5 + 4	14
	Start	Moves	End															
Bowl A	13	13 - 3 + 5	15															
Bowl B	16	16 - 4 + 3	15															
Bowl C	15	15 - 5 + 4	14															
6	23 [respondents]	<p>A survey is given to 90 people, and everyone chooses one of four options: 1) plays golf, but not tennis, 2) plays golf, but not tennis, 3) plays both golf and tennis, 4) plays neither. Based on the results, the probability that someone chose option 1 is $\frac{5}{18}$, the probability that someone chose option 2 is $\frac{1}{3}$, and the probability that someone chose option 3 is $\frac{2}{15}$. How many respondents chose option 4?</p> <p>$\frac{5}{18}(90) + \frac{1}{3}(90) + \frac{2}{15}(90) = 25 + 30 + 12 = 67$ and the rest play neither, so $90 - 67 = 23$.</p>																
7	8 [even integers]	<p>Twin primes are pairs of prime numbers that differ by 2, such as 3 and 5. Consecutive pairs of twin primes are two pairs of twin primes with no other pair of twin primes between them, such as (17, 19) and (29, 31), and these two pairs of twin primes have the even integers 20, 22, 24, 26, and 28 between them. What is the greatest number of even integers between any two pairs of consecutive two-digit twin primes?</p> <p>The two-digit pairs of twin primes are (11, 13), (17, 19), (29, 31), (41, 43), (59, 61), and (71, 73), and between 43 and 59, there are 8 even integers, 44, 46, 48, 50, 52, 54, 56, and 58.</p>																

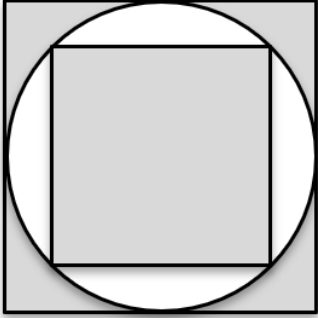
8	[A =] 126	<p>Let A be a positive three-digit integer in which the units digit is larger than the tens digit, and the tens digit is larger than the hundreds digit. What is the smallest value of A, such that four times A, or $4A$, is also a three-digit integer with three different digits and A and $4A$ have no digits in common?</p> <p>The smallest possible value of A is 123, so start checking numbers beginning with 123 $123 \cdot 4 = 492$, A and $4A$ have a 2 in common $124 \cdot 4 = 496$, A and $4A$ have a 4 in common $125 \cdot 4 = 500$, A and $4A$ have a 5 and $4A$ has two 0s $126 \cdot 4 = 504$, this one works, so the answer is 126</p>
9	[A + B =] 1711	<p>The second term of a six-term geometric sequence is 7 and the fifth term is 189. As a reduced common fraction, the sum of the first and sixth terms of the sequence is A/B. What is the value of $A + B$?</p> <p>$189/7 = 27$ so the numbers in the series are multiplying by 3 each time. The series is then, $7/3$, 7, 21, 63, 189, and 567. The sum of the first and sixth terms is $7/3 + 1701/3 = 1708/3$ and $1708 + 3 = 1711$</p>
10	[A + B + C =] 38	<p>The area of the small square that is inscribed in the circle is 9 cm^2. The combined area in cm^2 of all the shaded regions, including the small square is $A - \frac{B\pi}{C}$, where $\frac{B\pi}{C}$ is in terms of π and in lowest terms, and A, B, and C are positive integers. What is the value of $A + B + C$?</p>  <p>The side length of the small square is $\sqrt{9} = 3 \text{ cm}$, so the diagonal is $3\sqrt{2} \text{ cm}$, which is also the diameter of the circle and the side length of the large square. The area of the large square is $(3\sqrt{2})^2 = 18$ and the area of the circle is $(3\sqrt{2}/2)^2\pi = 9\pi/2$, so the total combined shaded area is $18 - 9\pi/2 + 9 = 27 - 9\pi/2$, and the answer is $27 + 9 + 2 = 38$.</p>

“Math is Cool” Masters -- 2022-23

6th Grade

College Bowl Round #1 Solutions

6th	Answer	Solution
1	8	What is forty percent of twenty percent of one hundred? 20% of 100 is 20, 40% of 20 is 8
2	[A + B =] 58	A jar contains eleven sugar cookies and seven oatmeal cookies. As a reduced common fraction, the probability that two randomly selected cookies from the jar are both oatmeal is A over B. What is the value of A plus B? $7/18 * 6/17 = 7/51$ and $7 + 51 = 58$
3	500,000 [square meters]	How many square meters are in one-half of a square kilometer? $1/2 * 1000 * 1000 = 500000$
4	312	Let WX and YZ each represent a two-digit integer. If the digits W, X, Y and Z are all different and none of them is zero, what is the smallest possible value of the product of WX and YZ? The smallest four digits are 1, 2, 3, and 4, so use combinations of these. To minimize the product, use 1 in the tens place for one and 2 in the tens place for the other. The product will be smaller the farther apart the numbers are, so $13 * 24$ will be smaller than $14 * 23$, and $13 * 24 = 312$.
5	6600 [hops]	Some kangaroos can travel thirty miles per hour and hop a horizontal distance of twenty-four feet. At these rates, how many hops would a kangaroo travel in one hour? The number of feet in a mile is 5280 ft, and $5280/24$ is 220 hops per mile. $220 \text{ hops/mile} * 30 \text{ miles/hour} = 6600 \text{ hops/hr}$.
6	[k =] 2	What is the value of K, such that the linear equation Y equals KX plus five has a solution point of two comma nine? The y-intercept of the equation $y = kx + 5$ is (0, 5), so to go through the point (2, 9) means a rise of 4 and a run of 2 and $4/2 = 2$, which is the value of k.
7	[D =] 1	If A plus three equals B and B minus four equals C, then A equals C plus D. What is the value of D? $A + 3 = B$ and $B - 4 = C$, so $B = C + 4$, and $A + 3 = C + 4$, so $A = C + 1$, and $D = 1$

8	63 [cats]	<p>The ratio of dogs to cats in an animal shelter is thirty-two to twenty-one. If there are one hundred and fifty-nine total dogs and cats in the shelter combined, how many of the animals are cats?</p> <p>$32 + 21 = 53$ and $159/53 = 3$, so there are $3 * 21 = 63$ cats</p>
9	320 [minutes]	<p>Let eighty divided by fifteen equal X. How many minutes are in X hours?</p> <p>$80/15 * 60 = 320$</p>
10	26 [minutes]	<p>The lengths of Fido's last three walks have been twenty-three, seventeen, and thirty-four minutes. How many minutes should the next walk be such that the average length of all four walks is twenty-five minutes?</p> <p>$23 + 17 + 34 + x = 25 * 4 \rightarrow 74 + x = 100 \rightarrow x = 26.$</p>

“Math is Cool” Masters -- 2022-23

6th Grade

College Bowl Round #2 Solutions

6th	Answer	Solution
1	2401	What is seven to the fourth power? $7^4 = 2401$
2	75 [minutes]	Ishan is looking for a needle in a haystack. It takes him five minutes to sift through two cubic feet of hay. How long, in minutes, does it take Ishan to sift through thirty cubic feet of hay? $30/2 = 15$ and $15*5 = 75$
3	7 [numbers]	How many composite numbers are there from forty to forty-nine, inclusive? 40, 42, 44, 45, 46, 48, 49, makes 7 composite numbers
4	6	What is the mean of the square root of one hundred, the cube root of one hundred twenty-five, and the fourth root of eighty-one? $\sqrt{100} + \sqrt[3]{125} + \sqrt[4]{81} = 10 + 5 + 3 = 18$, and $18/3 = 6$
5	81 [days]	It takes nine workers nine days to build nine walls. Working at the same rate, how many days does it take two workers to build eighteen walls? 9 workers, 9 days, 9 walls is equivalent to 1 worker, 81 days, 9 walls, so 2 workers would take 81 days to build 18 walls
6	120 [degrees]	The ratio of the angles in a triangle is one to three to eight. What is the angle measure, in degrees, of the largest angle? $x + 3x + 8x = 180$ $12x = 180$ $x = 15$ $8x = 120$
7	174 [tolls]	Each hour of the day one through twelve, a bell tolls the same number of times as the time of day. It also tolls eight times each hour to make a melody prior to tolling the time of day. How many total tolls are there in one twelve-hour stretch? $8*12 + 1 + 2 + 3 + 4 + 5 + 6 + 7 + 8 + 9 + 10 + 11 + 12 = 96 + 12(13)/2 = 96 + 78 = 174$

8	12	Twice my number minus half of my number equals eighteen. What is my number? $2x - 0.5x = 18$ $1.5x = 18$ $x = 12$
9	53	Evaluate one thousand three hundred seventy-eight divided by twenty-six. $1378/26 = 53$
10	87	The first three terms of an arithmetic sequence are three, seventeen, and thirty-one. What is the seventh term in the sequence? 3, 17, 31, 45, 59, 73, 87 or $3 + 14 * 6 = 87$

“Math is Cool” Masters -- 2022-23

6th Grade

College Bowl Round #3 Solutions

6 th	Answer	Solution
1	[A + B =] 59	<p>The median of all positive two-digit integers is A point B, where A is a two-digit integer and B is a single-digit integer. What is the value of A plus B?</p> <p>Since it's an arithmetic series, the average of the first and last numbers is the same as the median, so $10 + 99 = 109$ and $109/2 = 54.5$ and $54 + 5 = 59$</p>
2	[P - Q =] 1	<p>Alf is taller than Barb, Barb is taller than Cam, Doug, and Evy. As a common fraction, the ratio of persons who could be the shortest in the group to persons who could not be the shortest is P over Q. What is P minus Q?</p> <p>Cam, Doug, or Evy could be the shortest, Alf and Barb cannot be the shortest, so the ratio is $3/2$ and $3 - 2 = 1$</p>
3	6	<p>What is the remainder when three thousand twenty-one is divided by fifteen?</p> <p>$201 \cdot 15 = 3015$ and $3021 - 3015 = 6$</p>
4	28 [cm]	<p>The height of a triangle is four times the base. The area of the triangle is ninety-eight square centimeters. In centimeters, what is the height of the triangle?</p> <p>Let $h = 4b$, then $98 = 4b(b)/2 \rightarrow 2b^2 = 98 \rightarrow b^2 = 49 \rightarrow b = 7$, so the height is $4 \cdot 7 = 28$.</p> <p>$2/11 \cdot 9/10 \cdot 8/9 \cdot 3 = 48/110 = 24/55$, so $24 + 55 = 79$.</p>
5	[A + B =] 79	<p>In a group of eleven pickleballers, two are left-handed. As a reduced common fraction, the probability that exactly one of three randomly selected players is left-handed is A over B. What is the value of A + B?</p> <p>$2/11 \cdot 9/10 \cdot 8/9 \cdot 3 = 48/110 = 24/55$, so $24 + 55 = 79$.</p>
6	3 [values]	<p>A Mersenne prime is a prime number that can be expressed as negative one plus two to the power of a positive integer N. How many values of N from one to six inclusive result in Mersenne primes?</p> <p>$2^1 - 1 = 1$, $2^2 - 1 = 3$, $2^3 - 1 = 7$, $2^4 - 1 = 15$, $2^5 - 1 = 31$, $2^6 - 1 = 63$, and 3, 7, and 31 are primes, so the answer is 3.</p>

7	64 [feet]	<p>On Jeb's first six shots on a hole in miniature golf the ball gets closer to the hole by exactly half its remaining distance to the hole. After six shots, the ball is one foot from the hole. How many feet from the hole was the ball originally?</p> <p>In the series, 1, 2, 4, 8, 16, 32, and 64, 64 would represent the distance to the hole before his first shot.</p>
8	440 [yds]	<p>How many yards are in one fourth of a mile?</p> <p>$5280/3 = 1760$ yards in a mile: $1760/4=440$</p>
9	171 [elbow bumps]	<p>How many elbow bumps occur in a room of nineteen people if each person bumps elbows with every other person once?</p> <p>$18 + 17 + \dots + 2 + 1 = 19(18)/2 = 171$</p>
10	[x =] 4	<p>If three-halves X plus fifteen-halves equals twenty-seven halves, what is the value of X?</p> <p>$3x/2 + 15/2 = 27/2 \rightarrow 3x + 15 = 27 \rightarrow 3x = 12 \rightarrow x = 4$</p>

“Math is Cool” Masters -- 2022-23

6th Grade

College Bowl Round #4 Solutions

6 th	Answer	Solution
1	9 [factors]	<p>How many positive integer factors does the number one hundred have?</p> <p>The factors of 100 are, 1, 2, 4, 5, 10, 20, 25, 50, and 100, and there are 9 on them, or $100 = 2^2 * 5^2$, so the number of factors is $3*3 = 9$.</p>
2	133 [ft ²]	<p>A certain wall has an area of one hundred and seventy-one square feet. Biff paints two-ninths of the wall and Eho paints the rest. How many square feet are in the section that Eho paints?</p> <p>$7/9 * 171 = 7*19 = 133$</p>
3	38	<p>What is the mean of the following five numbers: ninety, forty, thirty, twenty, and ten?</p> <p>$90 + 40 + 30 + 20 + 10 = 190$ and $190/5 = 38$</p>
4	96 [in ²]	<p>A rectangle has dimensions twelve by thirty-two inches. Four triangles are created by drawing the diagonals. In square inches, what is the area of one of these triangles?</p> <p>All four triangles have the same area, so the area of any one of the triangles is $12(32)/4 = 96$</p>
5	4 [years old]	<p>Anya is four years older than Ben. Two years ago, Anya was three times Ben's age. How old is Ben right now, in years?</p> $\begin{cases} A = B + 4 \\ A - 2 = 3(B - 2) \end{cases} \Rightarrow$ $\begin{cases} A = B + 4 \\ A = 3B - 4 \end{cases} \Rightarrow$ <p>$B + 4 = 3B - 4 \Rightarrow$ $2B = 8 \Rightarrow B = 4$</p>
6	27 [min]	<p>Varun averaged thirty miles per hour driving to work. On his drive back home, he averaged twenty-four miles per hour, and it took three minutes longer than the drive to work. What was the total number of minutes spent driving to and from work?</p> <p>$D = rt$, $D = 30t$ and $D = 24(t + 3)$, so $30t = 24(t + 3)$, $30t = 24t + 72$, $6t = 72$, $t = 12$ and $t + 3 = 15$, $12 + 15 = 27$</p>

7	[N =] 5	<p>The first term of a decreasing geometric series is five hundred seventy-six, the second term is four hundred thirty-two, and the third term is three hundred twenty-four. The Nth term in the series is the first non-integer value. What is the value of N?</p> <p>576, 432, 324, 243, $729/4$, . . . so the 5th term is not an integer and N = 5</p>
8	38 [cups]	<p>Darli buys one cup of coffee every weekday, and two cups of coffee every Saturday and every Sunday. Assuming that June 1st is on a Monday, how many total cups of coffee will she buy during the month of June?</p> <p>$9 * 4 = 36$ $36 + 2 = 38$</p>
9	180 [ways]	<p>How many ways can you arrange the letters in the word "google", spelled G-O-O-G-L-E?</p> <p>$6! / (2! * 2!) = 180$</p>
10	349	<p>Eighty-seven point two five is twenty-five percent of what number?</p> <p>$87.25 * 4 = 349$</p>

“Math is Cool” Masters -- 2022-23

6th Grade

College Bowl Round #5 Solutions

6 th	Answer	Solution
1	[A + B =] 29	As a reduced common fraction, the probability of randomly drawing a red face card from a standard deck is A over B. What is the value of A plus B? Of the 12 face cards, 6 are red so $6/52 = 3/26$ and $3 + 26 = 29$
2	59	What is the largest prime factor of one thousand seven hundred and seventy? $1770 = 5 \cdot 3 \cdot 2 \cdot 59$
3	42 [minutes]	Neepa takes thirty minutes to complete five-twelfths of an assignment. At this rate, how many more minutes will she need to complete the rest of the assignment? $5/12 = 30 \text{ min} \rightarrow 1/12 = 6 \text{ min} \rightarrow 7/12 = 42 \text{ min}$
4	10 [units]	An isosceles right triangle has the same area as a rectangle with side lengths 10 and 5 units. What is the length of one of the legs of the right triangle in units? Area of the rectangle = $10 \times 5 = 50$. Triangle has area = $\frac{1}{2} (b)(h) = \frac{1}{2} \text{leg}^2 = 50$. $\text{Leg}^2 = 100$, therefore leg = 10 units
5	105 [bowls]	A certain ice cream shop has fifteen flavors. How many different bowls containing two different flavors are possible? ${}_{15}C_2 = 15 \cdot 14 / 2 \cdot 1 = 105$
6	6,000,000 [or 6 million]	As an integer, what is the product of one point five times ten to the negative third power and forty times ten to the eighth power? $1.5 \times 10^{-3} \cdot 40 \times 10^8 = 60 \cdot 10^5 = 6,000,000$
7	11 [widgets]	Three widgets cost the same as seven gizmos. Eleven gizmos cost the same as nine doodads. How many widgets cost the same as twenty-one doodads? $3w = 7g$ and $11g = 9d \rightarrow 33w = 77g$ and $77g = 63d$, so $33w = 63d$ or $11w = 21d$, so the answer is 11.
8	[n =] 49	If X equals two, Y equals five, and X times Y times N equals four hundred and ninety, what is the value of N? $2 \cdot 5 \cdot N = 490$, $10N = 490$, $N = 49$

9	21 [%]	In a survey of two hundred people about their favorite breakfast drink, eighty-six prefer plain water, twenty-two prefer juice, fifty prefer coffee, and the rest prefer tea. What percent of the people surveyed prefer tea? Water = 86, juice = 22, and coffee = 50, so $200 - 86 - 22 - 50 = 42$, and $42/200 = 21/100 = 21\%$
10	1331 [in ³]	In cubic inches, what is the volume of a cube with a side length of eleven inches? $11^3 = 1331$

“Math is Cool” Masters -- 2022-23

6th Grade

College Bowl Round #6 Solutions

6 th	Answer	Solution
1	15 [cents]	Baguettes cost two dollars and ninety-five cents each. Marina buys three baguettes with nine dollars. How many cents will she receive in change? $2.95 \times 3 = 8.85$ so there will be 15 cents left
2	24	Let A equal one, B equal two, C equal three, and so on, all the way up to Z equals twenty-six. What is the value of L plus E plus G? ABCDEFGHIJKL, $5 + 7 + 12 = 24$
3	[x =] 22	What does X equal if two hundred and fifty X minus four thousand equals one thousand five hundred? $250x - 4000 = 1500 \rightarrow 250x = 5500 \rightarrow x = 22$
4	[A + B =] 7	A circular spinner with five congruent sections numbered one through five is spun twice. As a reduced common fraction, the probability that the sum of the two resulting numbers is greater than six is A over B. What is the value of A plus B? There are 25 possible results of which there are 11 that add to more than 6, (2, 5), (3, 4), (3, 5), (4, 3), (4, 4), (4, 5), (5, 2), (5, 3), (5, 4), (5, 5). So, the probability is $10/25 = 2/5$, and $2 + 5 = 7$.
5	6 [minutes]	Elias takes fifteen minutes to mow the lawn. It takes Martina ten minutes to mow the same lawn. In minutes, how long would it take Elias and Martina working together to mow the lawn? $1/15 + 1/10 = 1/x \rightarrow 2x + 3x = 30 \rightarrow 5x = 30 \rightarrow x = 6$
6	13 [inches]	The surface area of a rectangular prism whose base has dimensions four inches by seven inches is three hundred and forty-two square inches. In inches, what is the height of the prism? $4 \cdot h \cdot 2 + 7 \cdot h \cdot 2 + 4 \cdot 7 \cdot 2 = 342 \rightarrow 8h + 14h + 56 = 342 \rightarrow 22h = 286 \rightarrow h = 13$
7	48	What is the median of the positive two-digit multiples of twelve that are not also multiples of seven? The two-digit multiples of 12 that are not also multiples of 7 are 12, 24, 36, 48, 60, 72, 96, and the median is 48

8	3 [players]	A basketball team has fifteen players. If eighty percent of the players are at least six feet tall, how many of the players are less than six feet tall? $0.2 * 15 = 3$
9	153 [nickels]	How many nickels are needed to make seven dollars and sixty-five cents? $765/5 = 153$
10	3	There are four mugs on a shelf, mug one, mug two, mug three, and mug four. Four is shorter than both one and three. Two is shorter than four, and one is shorter than three. Which number mug is the tallest? Four < one and three, two < four, and one < three, so three is the tallest.

“Math is Cool” Masters -- 2022-23

6th Grade

College Bowl Round EXTRA Solutions

6 th	Answer	Solution
1	1400 [cat GIFs]	A two hundred and fifty-six gigabyte hard drive can hold twelve hundred cat videos or forty-two hundred cat GIFs. The hard drive has eight hundred cat videos. Assuming the remaining space is available, how many cat GIFs can be added to the hard drive? Eight hundred is $\frac{2}{3}$ of 1200, so there is $\frac{1}{3}$ of the space left, and $\frac{1}{3}$ of 4200 is 1400.
2	81 [integers]	How many two digit positive integers are there which consist of two distinct digits? $9 \times 9 = 81$ Or, in total there are 90 2-digit integers. Subtract off 11, 22, ..., 99.
3	59 [minutes]	Eileen can make ten origami cranes every five minutes. Working at this rate, how many minutes would it take her to make one hundred and eighteen origami cranes? $10/5$ minutes = 2 per minute $118/2 = 59$ minutes
4	[A + B =] 17	As a reduced common fraction, the probability of rolling a prime number when rolling a twelve-sided die numbered one through twelve is A over B. What is the value of A plus B? 2, 3, 5, 7, 11 are five primes so the probability is $\frac{5}{12}$ and $5 + 12 = 17$
5	[A =] 320	The volume of a cone with a radius of eight centimeters and a height of fifteen centimeters is A times pi cubic centimeters. What is the value of A? $V = \pi r^2 h / 3 \rightarrow \pi \cdot 64 \cdot 15 / 3 = 320\pi$, so the answer is 320
6	[x =] -24	What is the value of X if ninety X plus one hundred twenty equals eighty-five X? $90x + 120 = 85x \rightarrow 5x = -120 \rightarrow x = -24$
7	10 [units]	On the coordinate plane, find the distance in units between the points two comma negative one and eight comma seven. (2, -1) and (8, 7) are 6 units away horizontally and 8 units away vertically, forming a 6-8-10 right triangle.